

LS800S Intruder Alarm System

Engineering Manual

Table of Contents

Section 1 – Overview of System

- 1.1 Kit Contents
- 1.2 Tools Required
- 1.3 System Features

Section 2 – Planning your installation

- 2.1 Location of components
- 2.2 Planning the location for the system components

Section 3 – Installation your system

- 3.1 Control Unit
- 3.2 Movement Detector/PIR
- 3.3 Door/Window Detector
- 3.4 Remote Key Reader
- 3.5 Bellbox
- 3.6 Testing the system

Section 4 – Using your system

- 4.1 Normal Operation
- 4.2 Learn the first remote keys
- 4.3 Select entry timer
- 4.4 Summary of the zones in different mode
- 4.5 Summary of Factory Settings
- 4.6 Status of LED indications

Section 5 – Maintenance

Section 6 – Extending your system

Section 7 – Specifications

SECTION 1 – OVERVIEW OF SYSTEM

The LS800S system is an indoor alarm system based on our patented two-wire technology to give exceptional levels of protection and reliability. It is a fuseless system with special electronic design for short-circuit protection. It is simple to use, easy to install, no special tools or training is required.

IMPORTANT – Please read this manual carefully, in full, before commencing Installation. You will find installation easier if you follow these steps in the sequence shown.

1.1 Kit Contents

The system comprises of:

★ CONTROL UNIT

This main unit receives signals from detectors, accepts input from users and activates warning devices.

★ MOVEMENT DETECTOR PASSIVE INFRA-RED (PIR) (Two units)

It senses body heat of moving person; one unit may cover entire room.

★ DOOR/WINDOW CONTACT (Three pairs)

Uses a magnetically operated switch to sense the opening of door or window.

★ REMOTE KEY (INFRA RED REMOTE KEY) (Two units)

They are pre-learned and used for operation commands to the Control Unit.

★ INFRA RED REMOTE READER

An extension of the infrared receiver to facilitate remote operation of the system from any convenient location.

The alarm kit also contains:

- Screw / wall plug pack.

To complete your installation, you also require: (You need to purchase separately)

- Rechargeable battery 12V, 1.2Ah or 2.0Ah
- Two core flat wires and clips.



PIR

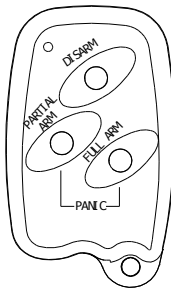

REMOTE KEY

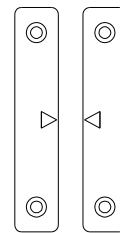

DOOR/WINDOW CONTACTS

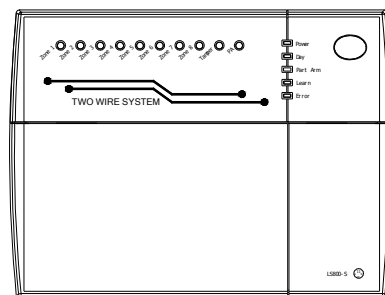

CONTROL UNIT

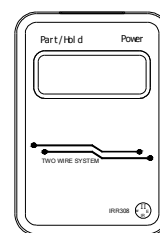

INFRA RED
REMOTE
READER

1.2 Tools Required

The following tools are required for installation:

- ★ Large & small flat bladed screwdrivers and cross point screwdriver:
- ★ Hammer
- ★ Power drill
- ★ Wire cutters and wire stripper
- ★ Eye protection (recommended when using a power drill or hammer)

1.3 System Features

- ★ Simple and effective Eight-zone system with the new patented two-wire technology.
- ★ All system components (sensors, bellbox) are connected to the Control Unit via two-core non-polarity flat wires. Wiring and installation of the system is extremely simple and easy.
- ★ Control Unit has built-in infrared receiver, with status LEDs and zone indicators. Panic and tamper attempts will be indicated by the status LEDs.
- ★ Maximum 8 remote keys can be accepted for full arm, part arm, disarm, panic and learn key functions
- ★ “Full arm” and “Part arm” modes are pre-programmed for user convenience.
- ★ The tamper zone is indicated by both Tamper LED and Zone LED (for Zone 4 to 8).
- ★ All sensors, bellbox are 24 hour line-protected and fully supervised; any attempt to interfere with the system will trigger the alarm and be identified by flashing LEDs and zone indicator.
- ★ Two PIR motion detectors can be connected to one zone, therefore the system can be expanded to have ten PIR’s plus many magnetic contacts. Also, easy connections are provided for adding telephone dialer to the system.
- ★ Remote key reader is available for user convenience.
- ★ Optional two wire bellbox is available
- ★ Optional normal bellbox connection terminals are provided.
- ★ Optional voice dialer is available to increase the security level.

SECTION 2 – PLANNING YOUR INSTALLATION

2.1 Location of components

Control Unit – Location

In choosing a suitable location you should bear in mind:

- ★ The user needs to reach the Control Unit or Remote Key Reader easily within the allocated time, when entering and leaving the premises.
- ★ The Control Unit should not be visible from the exterior of the protected premises.
- ★ All detectors and the bellbox must be wired to the Control Unit.

Having chosen the location do not mount at this stage.

Movement/Passive Infra Red Detector (PIR) – Location

- ★ The detector should not be mounted near to large metal objects or on metal surfaces. It needs to be mounted on a wall or in a corner at a height of approximately 2 to 2.5 meters for the best general coverage in an average room. The detector has been designed to avoid false alarms, nevertheless, it is best to avoid looking directly at sources of heat such as fires and boilers, and always try to keep away from a window. A PIR can look at a radiator but should not be sited above one.

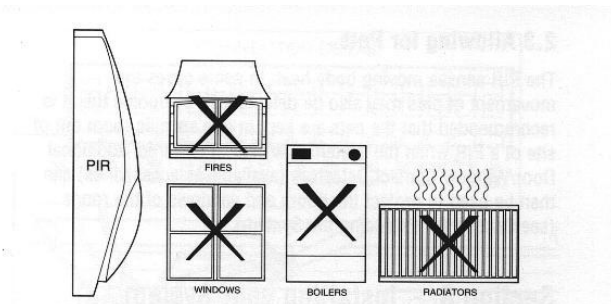

- ★ Do not site a PIR where its field of view may be obstructed (e.g. by curtains). Also note that PIRs work best when sensing movement across rather than along their detection beams. You need to consider the need to wire these units back to the Control Unit.

Detection Area of PIR

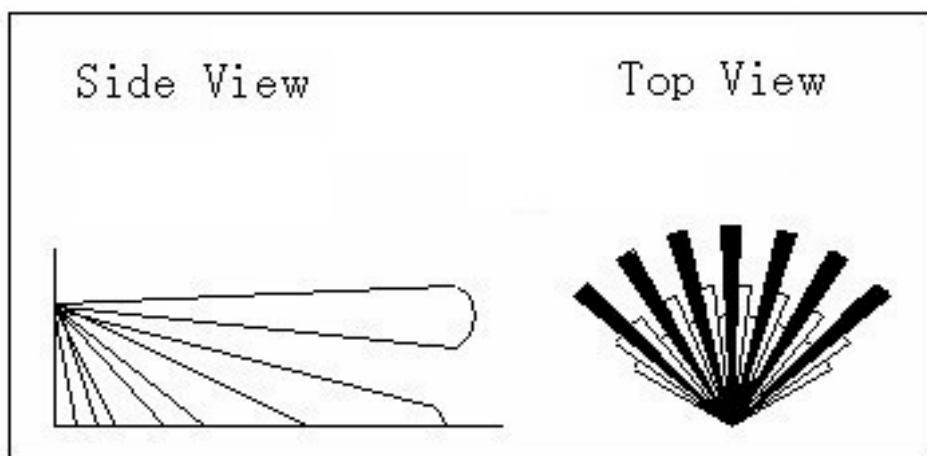

Having chosen the location do not mount at this stage.

Door/Window Contact Detectors – Location

- ★ Door / Window Contact Detector is designed to detect a door or window opening, so it is better mounted onto the frame with a magnet mounted next to it on the door or window.
- ★ In most applications one door contact is fitted to the front door and assigned to ZONE 1 which is the Entry/Exit Zone. When the system is set at “Full arm” mode, Zone 1 allows a 30 second (adjustable) delay for the user to enter or leave the house, and should be the only zone activated before reaching the Control Unit on entering the premises. The other contact detectors can be mounted to the back door or window and assigned to Zone 2 or 3.

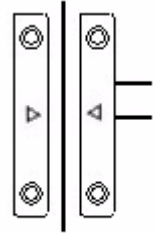

Having chosen the location do not mount at this stage.

Infra Red Remote Reader - Location

- ★ Choose a location near the most frequently entry/exit door, so that the arming and disarming of the system can be done conveniently when user exit/entry the premises.

Having chosen the location do not mount at this stage.

Two-wire Bellbox (Optional) – Location

- ★ Choose a location for the bellbox, preferably in a prominent position high up on an external wall, taking into account that it must be wired back to the Control Unit. The cable should ideally run directly from behind the bellbox through the wall to the inside. This is to avoid any cable running along the exterior wall that could be reached by an intruder.

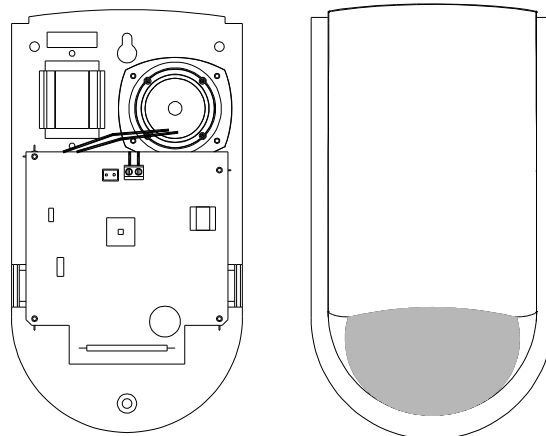

Having chosen the location do not mount at this stage.

2.2 Planning the location for the system components

Example of a domestic layout

The 2 sample layouts below are intended as guides only but demonstrate two examples of how a house can be protected with the system.

Sample 1: Two storey house

Legend

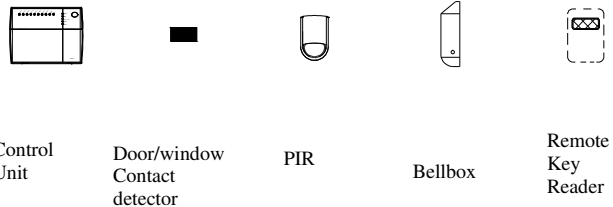

Zone	Area
1	Front Door
2	Back Door
3	Spare
4	Living room
5	Dining room
6	Kitchen
7	Bedroom #1
8	Bedroom #2,#3

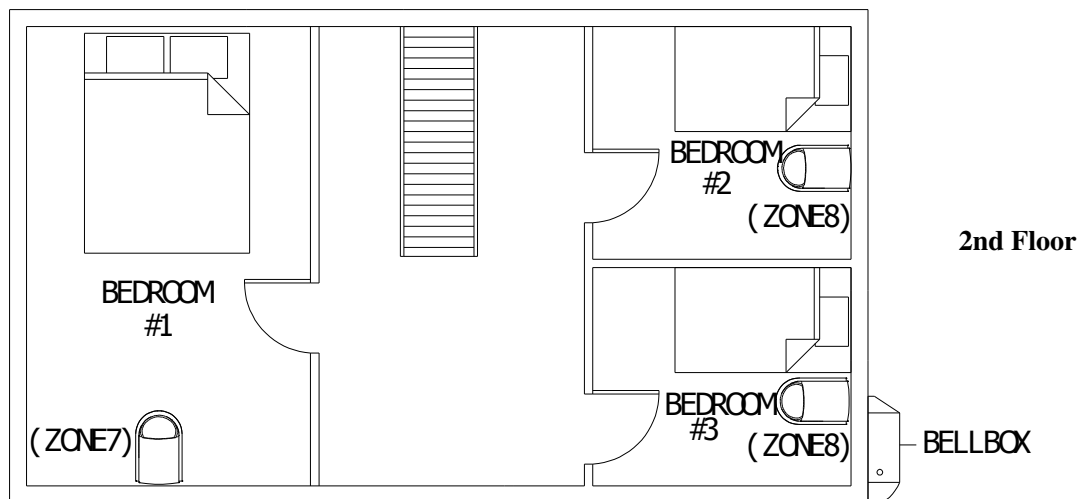
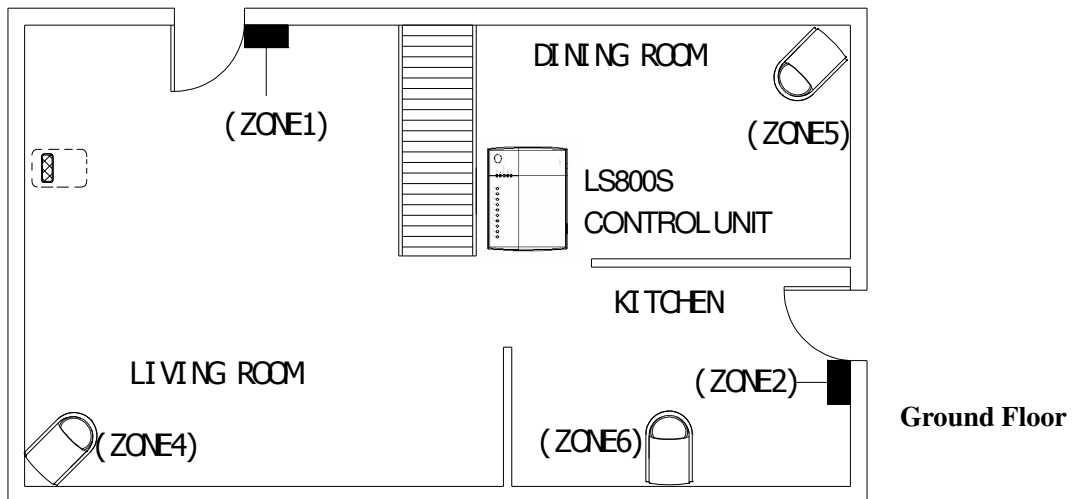

The PIRs have been placed in different rooms and those placed in bedrooms are only protected on full arm. The Door/Window Contact Detectors have been positioned to protect the front door and back door.

Sample 2: Single storey house

Zone	Area
1	Front Door
2	Back Door
3	spare
4	Hall
5	Spare
6	Kitchen
7	Bedroom#1
8	Bedroom#2

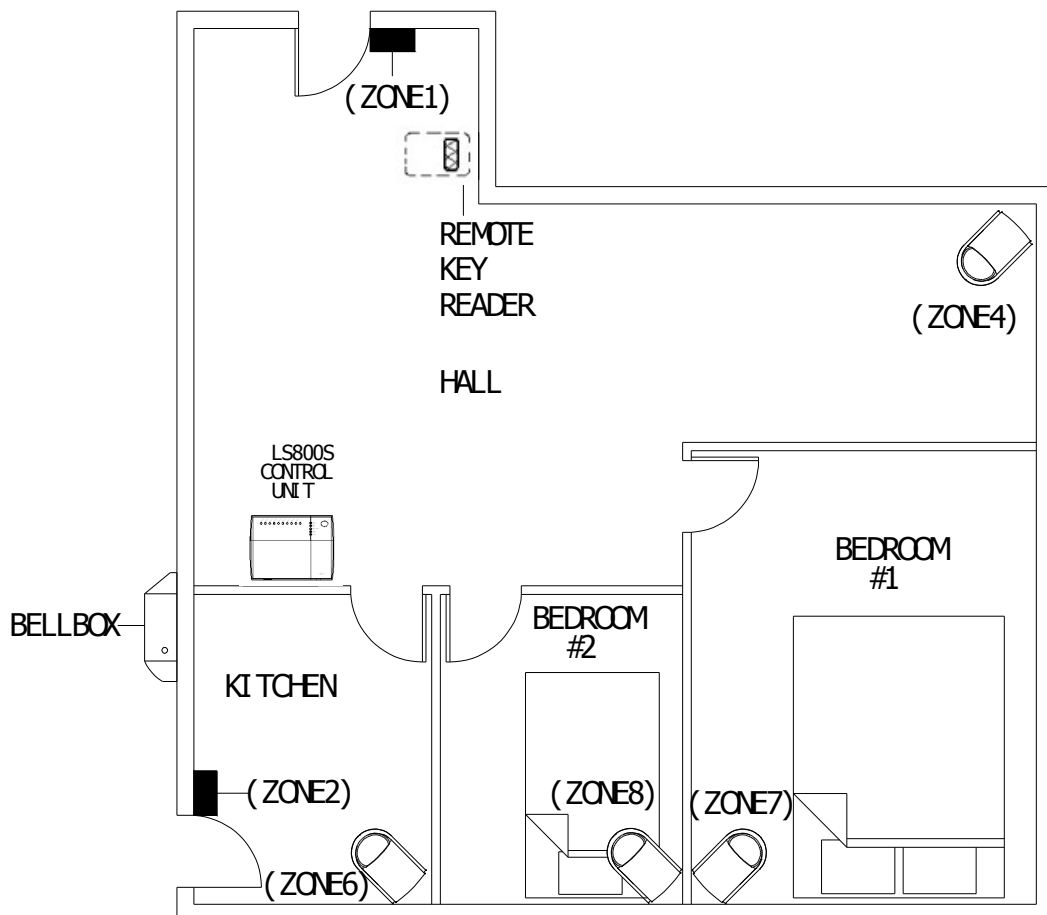

The Zone 4 PIR has been placed in the Dining/Living room to protect this general area. The Zone 7 and Zone 8 PIRs has been placed in bedrooms to protect the personal valuables there. They are disabled when the system is set at "Part Arm" mode. The Door/Window Contact Detectors have been positioned to protect the front door and back door.

SECTION 3 – INSTALLING YOUR SYSTEM

3.1 Control Unit

- ★ Remove and retain the two holding screws from the bottom of the front cover and carefully hinge off the front cover of the control unit.
- ★ Mark and drill holes for the three mounting screws. Put in the wall plugs and have a mounting screw on the top (hanging screw) inserted. Hang the Control Unit on the hanging screw and fixed it with two screws on the bottom. (Illustration 1)

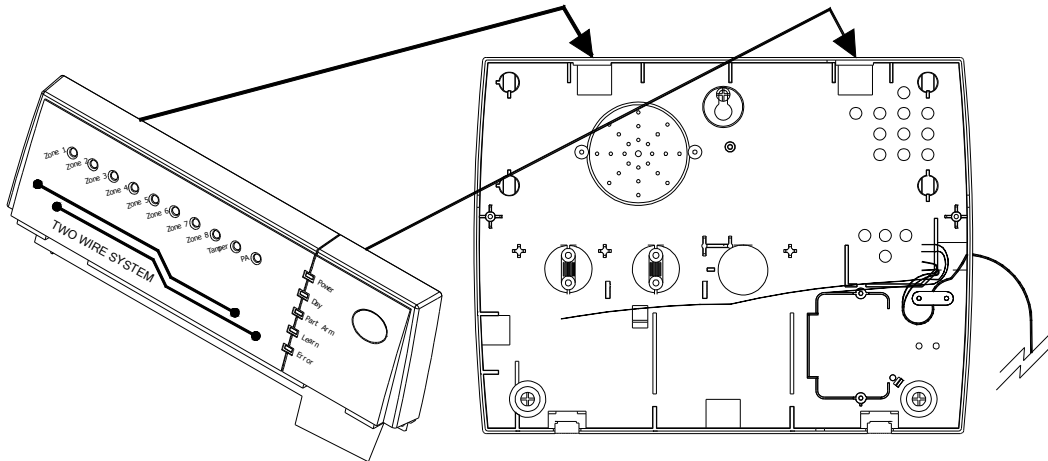

Illustration 1

- ★ Fix the upper part of the front cover on the bottom. (Illustration 1)
- ★ Connect the rechargeable battery on to the control unit and fix it by the battery clips. (Illustration 2)

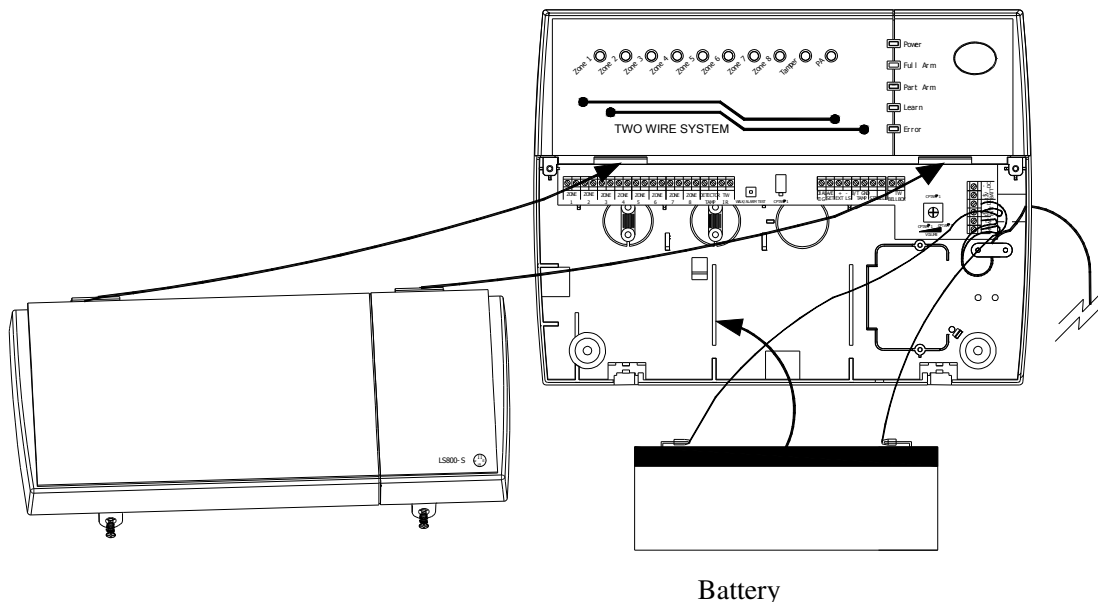

Illustration 2

- ★ Have all the sensors (magnetic contacts, PIRs) and optional accessories (Bellbox, or dialer if fitted) wired up and connected to the corresponding terminals in the Control Unit (Illustration 3). Also wire up the main power adapter and rechargeable battery to the

Control Unit. **DO NOT plug in** the power plug to the main supply until all connections are completed and all units properly mounted and front cover of the Control Unit is closed and secured.

WARNING: All connection to the mains should be made in accordance with all relevant wiring regulations. The Control Unit must never be operated from the mains with the front cover removed.

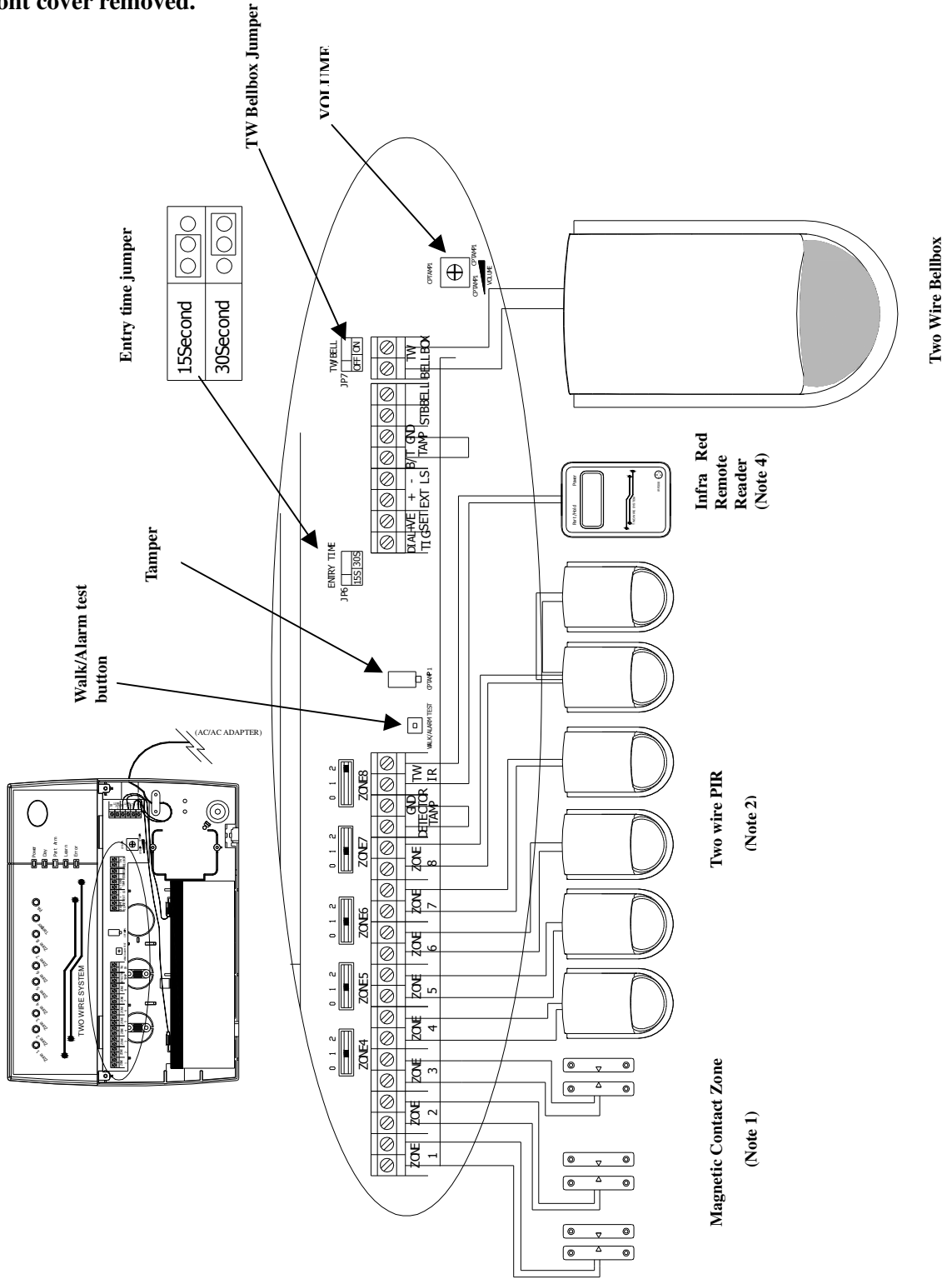

Illustration 3

NOTE 1: For connecting magnetic contacts to any of Zone 1-3, (For more information please refer Illustration 10).

NOTE 2: Illustration 3 show one piece of 2-wire PIR detector is connected to each of Zone 4 to Zone 7; and therefore the PIR zone slide switches opposite the PIR zone terminals are put in position 1. For connecting two pieces of PIR on the same zone (Zone 8), you need to put the corresponding slide switch to position 2. (For more information please refer Illustration 7)

NOTE 3: If you need to skip the PIR zone, you need to put the corresponding slide switch to position 0. (Factory setting)

NOTE 4: If more than one Infra Red Remote Reader is used, they can be connected in parallel, as shown in Illustration 7.

3.2 Movement Detector/PIR

- ★ Remove and retain the screw from the bottom of the PIR and lift off the cover.
- ★ Carefully remove the electronic module from its retaining clips, ensuring **not to touch the pyroelectric sensor** (Illustration 4).

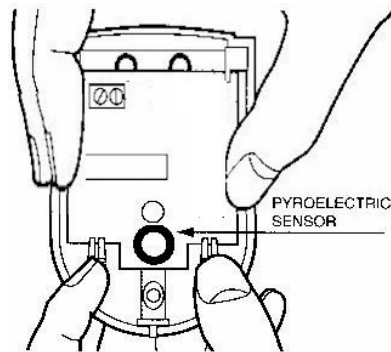

Illustration 4

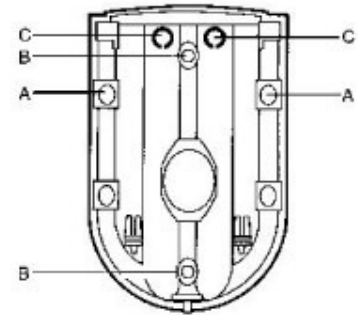

Illustration 5

- ★ Use mounting points “A”, if you are fitting the detector in a corner. Use mounting points “B”, if you are fitting the detector on a flat surface. Use a small drill to create two fixing holes at the mounting points (Illustration 5).
- ★ Hold the base of the PIR in the chosen position, ensuring that the front of the PIR will face towards the center of the protected area, mark and drill two fixing holes in the wall.

Choose one of the cable entry holes “C” and make a third hole in the detector base. Put one end of the 2-core wire through this hole “C”, then secure the PIR to the wall using two screws and wall plugs provided.

- ★ Replace the electronic module into the retaining clips, ensuring that it is correctly positioned and firmly seated.
- ★ If required, select the PIR LED “ON” or “OFF” option and the sensitivity (pulse count) by setting the corresponding jumpers on the electronic module. Note that Pulse 1 option is more sensitive than the pulse 4 option. Pulse 1 option is used when it is necessary to activate an alarm on the first detected pulse, or in high security installations – where fast “catch” performance is of greatest importance. Pulse 2 or 4 settings provides improved protection against false alarms caused by all types of environmental disturbances. (Illustration 6)

Connect the two wires to these two screw terminals

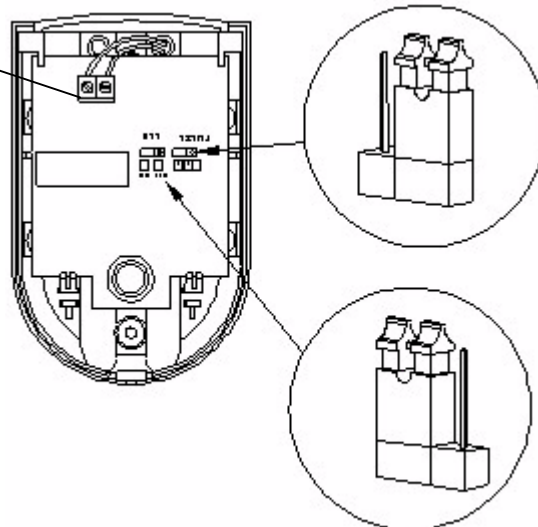

Illustration 6

Pulse Count	
Pulse 1	
Pulse 2	
Pulse 4	

LED	ON	
LED	OFF	

- ★ Connect the 2 wires to the PIR, polarity is not important.
- ★ Run the cable back to the Control Unit, fixing the cable with cable clips and enter the wire into the back of the Control Unit through any convenient cable hole.
- ★ Connect to one of the two wire PIR zone (zone 4 to zone 8) terminals in the Control Unit as required. Connection polarity is not important. (Illustration 3).
- ★ In the Control Unit, against each of the two-wire PIR connection terminals (zone 4 to zone 8), there is a 3-position (0,1,2) slide switch. These switches are factory pre-set at position “0” when no PIR is connected. When connecting one piece two-wire PIR to the zone, you need to set the corresponding switch to position “1”. When connecting 2 pieces two-wire PIR to the same zone terminals, put the corresponding switch to position “2”. The wiring to connect two PIRs to one same zone terminals are as Illustration 7.

- When the two PIRs are running in the same direction:

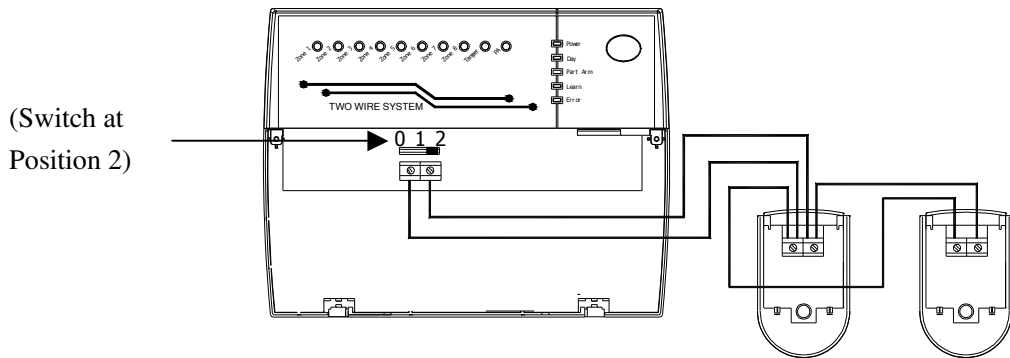

- When the two PIRs are running in opposite directions:

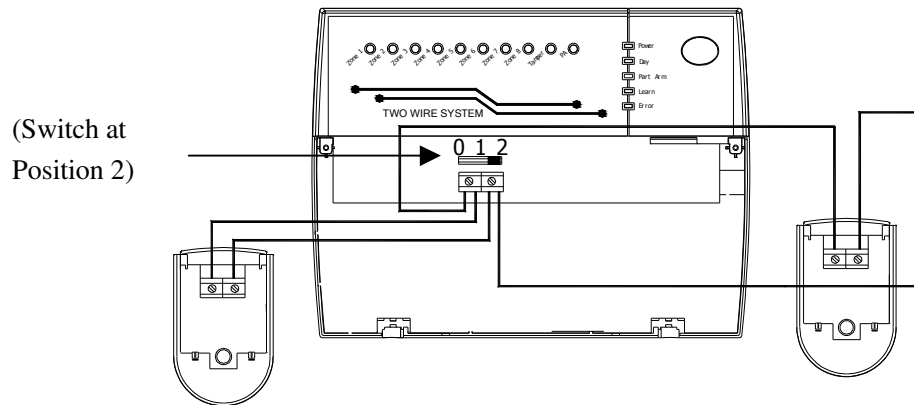

Illustration 7

- ★ Replace cover on PIR and refit the retaining screw.

3.3 Door/Window Contact Detector

- ★ Choose the location for each magnetic contact (remembering the need to wire them back to the Control Unit). Each contact consists of a magnetically-operated switch (with screw terminals at the back) and a magnet in an identical housing.
- ★ The switch (the part with screw terminals and cable) should be mounted on the frame. The magnet should be mounted on the door or window itself directly opposite the switch, no more than 8mm apart when the door or window is closed (Illustration 8). Mark two mounting holes for the magnet on the door or window and two mounting holes for the switch on the frame.

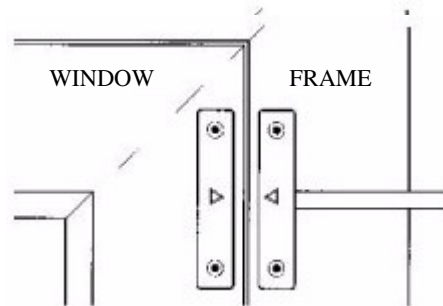

Illustration 8

- ★ Choose a convenient entry point for the cable on the switch housing and carefully remove part of the plastic using a sharp knife to create a hole (Illustration 9). Connect the 2 wires to the two screw terminals.

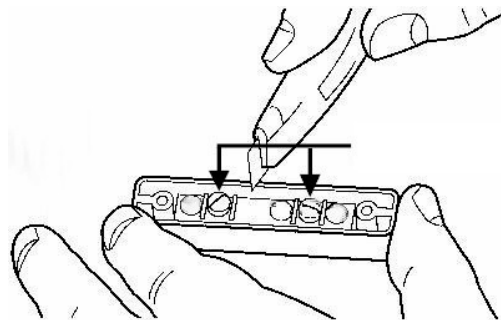

Illustration 9

- ★ Fixed the contact and magnet in position using the four mounting screws provided.
- ★ Run the cable back to the Control Unit.
- ★ Connect to zone 1, zone 2 or zone 3 terminals of the Control Unit as required. Connection polarity is not important.
- ★ If two magnetic contacts need to be wired to one same zone (zone 1, zone 2 or zone 3), wire them up in serial connection as Illustration 10.

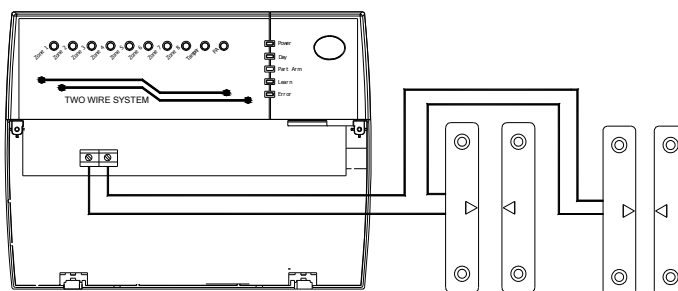
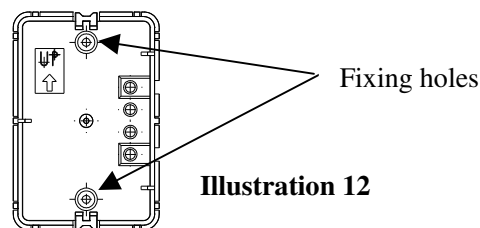
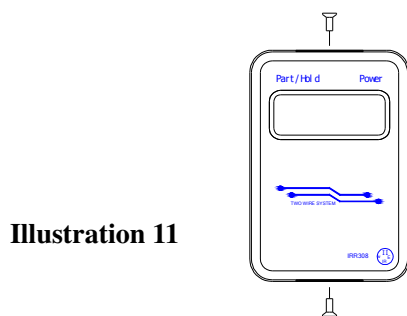

Illustration 10

3.4 Infra Red Remote Reader

- ★ Remove the cover retaining screws from the top and the bottom of the Reader cover (Illustration 11). Take off the cover from the reader baseplate.



- ★ Use the reader baseplate as a template to mark and drill fixing holes (Illustration 12) on the wall at the chosen position.
- ★ Mount and fix the baseplate of the reader with the screws and wall plugs provided.
- ★ Connect the 2-wire cable to the terminals inside the Infra Red Remote Reader, and the other end of the cable to the corresponding terminals in the Control Unit. (See Illustration 3). Maximum 3 Remote Key Readers may be connected in parallel.
- ★ Replace cover on the Reader and refit retaining screws.

3.5 Two wire Bellbox TW-972 (Optional)

- ★ Remove the cover retaining screw from the base of the bellbox cover (Illustration 13). Take off the cover from the bellbox baseplate.

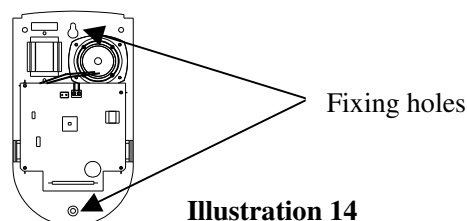
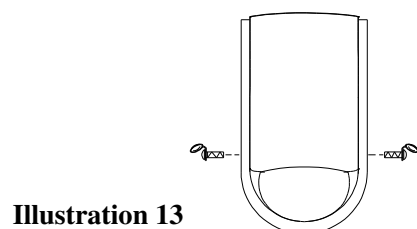

- ★ Use the bellbox baseplate as a template to mark and drill fixing holes (Illustration 14) on the wall at the chosen position. For mounting the bellbox outside the house, drill a further hole through the wall directly behind the bellbox for the 2 core cable to run through from the Control Unit to the bellbox.
- ★ Mount and fix the bellbox with the screws and wall plugs provided.
- ★ Connect the 2-wire cable to the terminals inside the bellbox, and the other end of the cable to the corresponding terminals in the Control Unit. (See Illustration 3).
- ★ Replace cover on the bellbox and refit retaining screws.
- ★ Put the TW bellbox jumper on the control panel to the ON position. (See Illustration 3).

(For details please refer to the TW-972 Two Wire Bellbox instruction)

3.5 Testing the system

- ★ After installation is completed, plug in the main power supply. The “Power” indicator will illuminate showing that the system is starting to work. Wait about two minutes for the system to get ready.
- ★ **Walk tests** – each detector to be checked in order to verify they are functioning correctly.
 1. Open the bottom cover of the control unit. Note that the tamper alarm appears. You may adjust the beep sound by adjusting the VOLUME by a small screw driver.(Illustration 3)
 2. Press the ‘DISARM’ button on the recognized remote key to stop the alarm. Tamper LED ‘**ⓧ** Tamper’ will flash to give tamper indication.
 3. Press the PCB mounted WALK/ALARM TEST push button momentarily. (Illustration 3) The system will go into walk test. Day LED is flashing.
 4. Upon activation of any zone, the relevant Zone LED ‘**ⓧ**’ will latch up and a ‘Zone fault’ tone (continuous short beeps) is emitted.
 5. Pressing the push button again at any time will clear the latched LED and walk test is restarted.
 6. On completion of walk test, close the cover of the control unit and an ‘OK’ tone (two rapid beeps) is emitted and Day LED is on.
- ★ **Alarm tests** – test the strobe, siren, low and high volume sounders of the system, SET output.

N. B. Alarm test may be activated while in walk test mode (go straight to step 3)

 1. Open the bottom cover of the control unit. Note that the tamper alarm appears.
 2. Press the ‘DISARM’ button on the recognized remote key to stop the alarm. Tamper LED ‘**ⓧ** Tamper’ will flash to give tamper indication.
 3. Press the PCB mounted WALK/ALARM TEST push button for 3-5 seconds. (Illustration 3). Day LED is flashing.
 4. The tests are performed consecutively. Advance to next test automatically after 3 seconds
 - a) Low volume sounder on LS800S control panel
 - b) High volume sounder on LS800S control panel and strobe
 - c) External bell and strobe
 - d) Set terminal +ve output and strobe
 5. On completion of walk test, close the cover of the control unit and an ‘OK’ tone (two rapid beeps) is emitted and Day LED is on.

SECTION 4 – USING YOUR SYSTEM

4.1 Normal operation

Normal operation with the remote key, such as full arm, part arm, disarm, panic and learn a new remote key function are described in the “**LS800S Security System Operation Manual**”

N.B. Remote keys provided are factory pre-learnt. Learning procedure is not necessary.

4.2 Learn the first remote keys

When all the remote keys are lost or not recognized by the LS800S system, you may need to re-learn all remote keys into the system. The control panel will remove all registered keys previously learned.

Ensure a wire is connected between first terminal of Zone 1 and Set terminal.

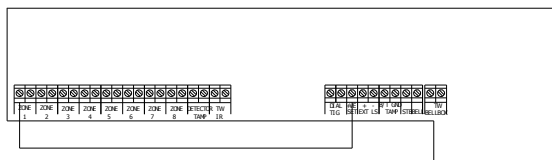

Power up LS800S control panel.

Learn LED is flashing.

The panel is in **LEARN** mode.

Only zone 1 LED is flashing indicates the first remote keys is going to be learned.

N.B. The learn mode will NOT expire until the first remote key is learned.

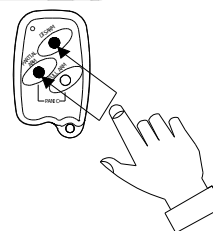
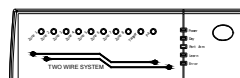
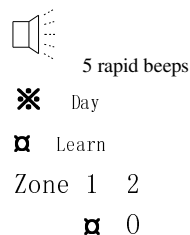

Press PART ARM button and DISARM button simultaneously on a new remote key.

A recognized beep and the flashing LED is changed to steady. The next numbered zone LED is flashed.

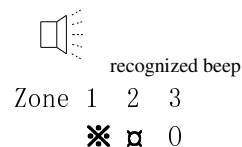

Repeat previous step to learn other new remote key.

The LEARN mode will be exited after 10 seconds timeout if no action is taken to learn new remote key.

Remove the wire between Zone 1 and Set terminals.

N.B. LS800S can learn up to 8 remote keys.

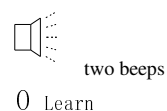

4.3 Select Entry Timer

The entry timer jumper on the control panel (See Illustration 3) is set to 30 seconds (default setting) which allows user to enter the premises and unset the system within 30 seconds.

User may put the entry timer jumper on the control panel to 15 seconds which allows user to enter the premises and unset the system within 15 seconds.

4.4 Summary of the zones in different mode

Zone	Full Arm	Part Arm	Usage
1	Delay	Delay	Exit/Entry zone
2	Instant	Instant	Protect door/window which are not often used
3	Instant	Instant	Protect door/window which are not often used
4 (TW-PIR)	Delay	Delay	Protect area close to exit/entry zone
5 (TW-PIR)	Delay follower	Delay follower	Protect area on the path between control unit and exit/entry zone
6 (TW-PIR)	Instant	Instant	Protect area when part arm is used
7 (TW-PIR)	Instant	Omit	Protect area for full arm only
8 (TW-PIR)	Instant	Omit	Protect area for full arm only

4.5 Summary of Factory Settings

	Factory Preset	Can be changed by User to	Manual Reference
Control Unit			
(1) Learn Remote Key	2 pre-learned	Additional 6 keys	Section 4.1
(2) Instant Zones	Zone 2,3,6 Zone 7,8 (Full arm)		
(3) Delay Zones	Zone 1,4		
(4) Delay Follower Zone	Zone 5		
(5) Omit Zones	Zone 7,8 (Part arm)		
(6) Entry Delay time	30 sec.	15 or 30 secs	Section 4.3
(7) Exit Delay time	30 sec		
(8) Siren Duration	20 minutes		
(9) PIR Slide Switch Position	Position "0"	0, 1 or 2 according to the number of two-wire PIRs connected	Section 3.2 (Illustration 7)

PIR Movement Detector			
(1) Test LED Jumper	"ON"	ON or OFF	Section 3.2 (Illustration 6)
(2) Pulse Count Jumper	Pulse 2	Pulse 1, 2 or 4	Section 3.2 (Illustration 6)

4.6 Status of LED indications:

STATUS LED	INDICATIONS
“Power” LED On	A/C power in use
“Power” LED flashing	Back-up battery in use.
“Day” LED illuminated	System “disarmed” (unset), ready to accept User commands by remote key.
“Day” LED Off	System armed (set). With “Part Arm” LED Off means Full Arm and all 8 zones are active.
“Part Arm” LED illuminated	System armed (set) with INSTANT Magnetic Contacts and DELAY two-wire PIRs, but Omit zone will be inactive (i.e. detectors in the Omit Zone (7 and 8) will be disabled, e.g. at night with people inside house)
“Learn” LED flashing	System in Learn mode and ready for new remote key register.
“Error” LED illuminated	Unregistered remote key command is detected.
Zone LED illuminated	Trigger detected on the corresponding zone. If more than one zone have been triggered, the first triggered zone will be flashing.
“Tamper” Led illuminated	Tamper detected on the system. With Zone Indicator(s) for the tampered zone(s).
“PA” LED illuminated	Panic signal is detected.

SECTION 5 – MAINTENANCE

Once every three months,

- ★ Test all detectors.
- ★ Check loudspeaker of control unit.
- ★ Test sirens and strobes of the bellbox.

Additionally, once every year,

- ★ Replace the batteries of the remote keys

Additionally, once every three years,

- ★ Replace the rechargeable battery in the Control Unit.

SECTION 6 – EXTENDING YOUR SYSTEM

A number of accessories are available to expand your system to suit your exact requirements.

- ★ **Movement Detector/ Two wire PIR** – covers a large area, easy to wire.
- ★ **Door/Window Contact Detector** – small, robust and reliable.
- ★ **Remote Key** – additional remote key for family member to operate the system.
- ★ **Remote Key Reader** – additional key reader for convenient access and operation of the system.
- ★ **Auto Voice Dialer** – will phone you when your premise is alarmed. There is a simple wiring to the Control Unit and the dialer.
- ★ **Two Wire Bellbox (TW972)** – to provide a high volume alarm and visual warning device, easy to wire.
- ★ **Impactor** – a shock sensor for protection on the break-in from closed windows or glass doors.

SECTION 7 – SPECIFICATIONS

Control Unit

Type	Microprocessor based control unit with patented two-wire technology
Housing	Polycarbonate
Zones	8 Alarm Zones (3 Intruder zone; 5 Patented two wire Intruder zone)
Exit Delay	30 seconds
Entry Delay	15 or 30 seconds selectable
Siren Duration	20 minutes
Remote keys	8 (maximum)
Remote key readers	3 (maximum)
Current consumption	Standby 100mA, Alarm 650mA.
Set Output	0V in Day, 12V in Arm
Dial trigger Output	5V normal, 0V after trigger
Siren/Strobe Outputs	12V
Aux Output	12V

Infra Red Remote Key

Type	Battery operated infra-red signal transmitter
Housing	ABS
Operational distance	Up to 12m
Operational Voltage	3V
Battery type	CR2032

PIR

Type	Dual Pyroelectric element with hemispherical lens and patented two-wire technology
Housing	ABS
Adjustments	Pulse Count (1, 2 or 4)
Test LED	Selectable (on/off)
Mounting height	2-2.5m
Detection Range	Up to 15m

Door/Window Contact Detector

Type	Magnetically - actuated switch
Housing	ABS

Infra Red Remote Reader

Type	Infra-red signal receiver and patented two-wire technology
Housing	ABS
LEDs	Power indication Part arm or alarm hold status
Sound	Entry/exit delay, arm/disarm confirmation, alarm