

Hercules 10 Zone onboard LED Alarm Panel Engineering Manual

SAFETY

Before proceeding with the installation, please note the following safety warnings:

DO NOT connect the mains supply directly to the product, this will cause permanent damage to the products.

Control panel is for indoor use only. Avoid mounting location which can expose this product to splashing or dripping liquid.

Always follow the manufacturer's advice when using any tools power tools, ladder/steps, using steps or ladders, and wear suitable protective equipment (e.g. safety goggles) when drilling holes, etc. The use of ear defenders are advisable when working in close proximity to the External Siren or the Control Panel's Siren when the front panel cover is removed due to the high sound level produced by it. Before drilling holes in walls, check for hidden electricity cables and water pipes. The use of a cable/pipe locator is advisable if in doubt. Batteries (battery pack or batteries installed) should not be exposed to excessive heat. Danger of damage to the unit may occur if battery is incorrectly replaced. Replace only with the same or equivalent type. (Do not mix batteries type).

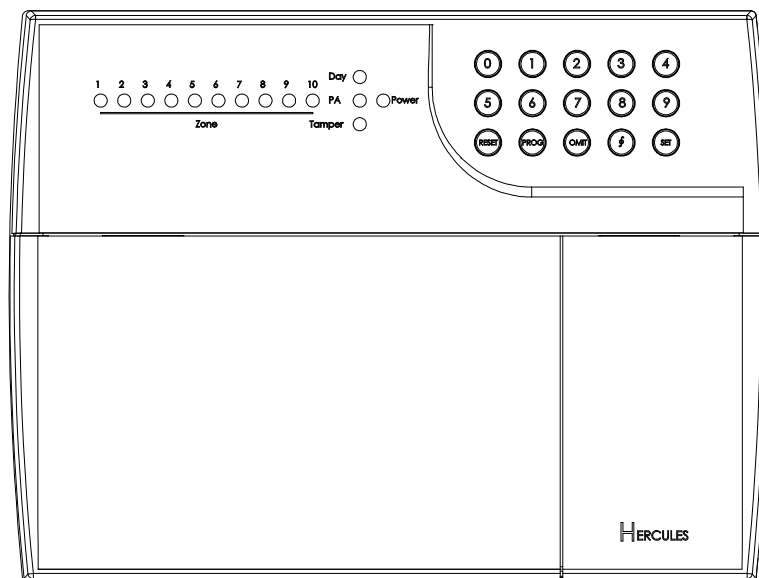

Table of Contents

SECTION 1 - OVERVIEW OF SYSTEM	5
1.1 - Kit Contents.....	5
1.2 - Tools Required	6
1.3 - System Feature.....	6
1.4 - Explanation of Terms	6
SECTION 2 – INSTALLING YOUR SYSTEM.....	7
2.1 - Fixing the Control Panel	7
2.2 - PCB	8
2.3 - Tamper network	8
2.4 - Remote Keypads	9
2.5 - Security Zones.....	10
2.6 - Fire Zone Circuit.....	10
2.7 - Tamper Zone Circuit.....	11
2.8 - PA Zone Circuit	11
2.9 - Extension speaker	11
2.10 - External siren Output (Bell box)	12
2.10.1 - Vortex II wiring to control panel	13
2.10.2 - Solar bell wiring to control panel.....	14
2.10.3 - AD2510 wiring to control panel	15
2.11 - 13V Supply Output	15
2.12 - Set	15
SECTION 3 - FACTORY DEFAULT SETTING.....	16
SECTION 4 - MAINS CONNECTION	17

SECTION 5 - FIRST POWER UP	18
SECTION 6 – HOW TO SET UP THE SYSTEM	20
6.1 - How to enter Engineer Program Mode.....	20
6.2 - Setup Programs.....	21
6.2.1 - How to go into Full mode Setting.....	21
6.2.2 - How to go into Part 1 mode Setting.....	21
6.2.3 - How to go into Part 2 mode Setting.....	21
6.2.4 - How to set zone function	22
6.2.5 - How to set Exit mode function	24
6.2.6 - How to set Exit time function	25
6.2.7 - How to set Entry time function.....	25
6.3 - Setup Zones Type.....	26
6.3.1 - How to set Zone Type.....	26
6.4 - Setup Zones Attrs.....	27
6.5 - Setup Codes	28
6.5.1 - How to set up/change User Code.....	29
6.5.2 - How to delete User Code	29
6.6 - Setup system	30
6.6.1 - How to Setup System Flags	30
6.6.2 - How to Setup Bell Time	33
6.6.3 - How to Setup Rearm count.....	33
6.6.4 - How to Setup Bell delay time	34
6.6.5 - How to Restore to factory value using menu.....	35
6.7 - View Event Log	35
6.8 - Test System.....	36
6.8.1 - How to Test Outputs	36
6.8.2 - How to enter Walk Test	37
6.8.3 - How to Exit Engineer Program Menu.....	37
SECTION 7 - USING SYSTEM.....	38
7.1 - Setting the System.....	38
7.2 - How to OMIT a zone(s).....	39
7.3 - Unsetting the System.....	39
7.4 - How to UNSET from Alarm and RESET the system	40

7.5 - How to use Panic Alarm on keypad	40
SECTION 8 - MAINTENANCE	41
SECTION 9 - TROUBLESHOOTING GUIDE.....	41
SECTION 10 - SPECIFICATIONS	43
APPENDIX 1 – ZONE - LOCATION TABLE	44
DISPOSAL AND RECYCLING.....	44
TECHNICAL SUPPORT	44

Section 1 - Overview of System

The 10 zone intruder alarm system is an indoor alarm system based on advanced technology to give professional levels of protection and reliability. It is 10 zone wired system with special electronic design for short-circuit protection. It is simple to use, to be installed by special installation engineer, special tools or training is required.

IMPORTANT – Please read this manual carefully, in full, before commencing Installation. You will find installation easier if you follow these steps in the sequence shown.

1.1 - Kit Contents

The system comprises of:

10 Zone onboard LED Alarm Panel.

This is the heart of the system. It receives signals from detectors. Accepts input from a user and activates warning devices such as siren and strobe lights.

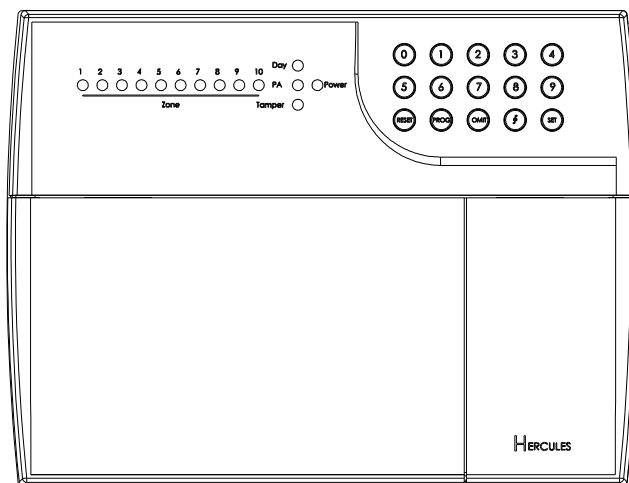

Option : LED REMOTE KEYPAD

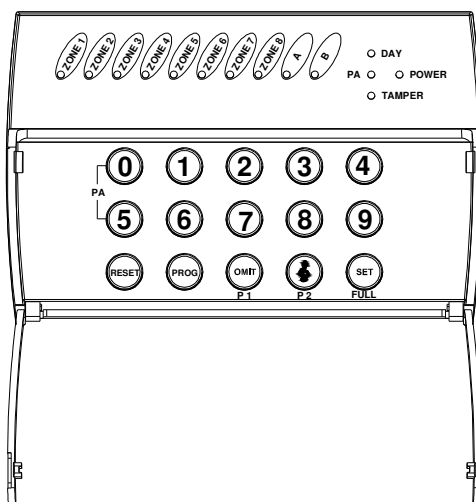

1.2 - Tools Required

- Large and small flat bladed screwdrivers
- Large and small cross-point screwdrivers
- Power drill
- Hammer
- 5mm, 8mm and 10mm masonry drill bits
- Sharp knife
- Wire cutters & wire stripper
- Ladder or other safe working platform

1.3 - System Feature

- 10 Zones programmable for Security, PA, Fire, 24Hr Tamper
- TAMPER input
- Output for External Bell Box and Strobe
- 4 Access Level Codes, manager code, engineer code, user code (2 user codes), holiday code, all programmable.
- 1 Full set and 2 fully selectable part set programs.
- Chime on any security zone
- 16 events memory for LED Keypad
- Programmable timers for exit, entry and bell cut off
- Walk Test mode
- Quick set system
- Single Key Set mode
- Supports up to four remote LED keypads with on board PA , Keypads positioned up to 100 meters from control panel.
- Keypads can be wired in a star configuration from control panel
- Single key set
- Non-voltage memory for protection of engineer program, manager and event log.
- Battery capacity of up to 2.1AH

1.4 - Explanation of Terms

Zone – A logical area that is monitored by one or two or more detectors.

Disarm – It is the normal state of the system when the house is occupied. Enter your four-digit user PIN code would return to OFF state.

Full Alarm (ARM state) – The CU will sound full alarm (internal siren) when it receives alarm signals.

Part Arm (Home state) – Arming the system so that certain zones omitted (i.e. will not trigger an alarm).

Entry/Exit Zone – The CU recognize MC zone as entry and/or exit zone.

OK Beep – Rapid double tone; it indicates correct operation.

Error Beep – Long single tone; it indicates incorrect operation.

Section 2 – Installing your System

In choosing a suitable location you should bear in mind:

- The need to reach the CU easily, within the 30 seconds, when entering and leaving the premises, ideally passing only one detector.
- The CU should not be visible from the exterior of the protected premises.

2.1 - Fixing the Control Panel

CAUTION: When positioning the control panel ensure that it is located in a dry place away from damp areas.

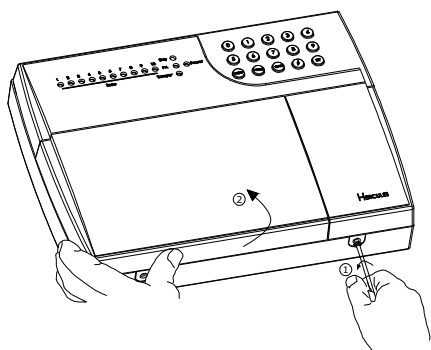

Step 1. Remove the front cover(s) from the base assembly.

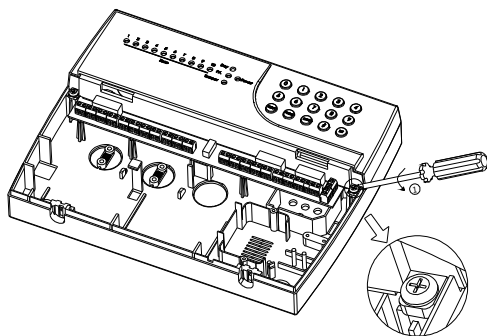

Disconnect the transformer wires from the board, these are marked AC. Carefully remove the board by gently pushing the holding clips on the bottom edge of the board and with draw it from the base.

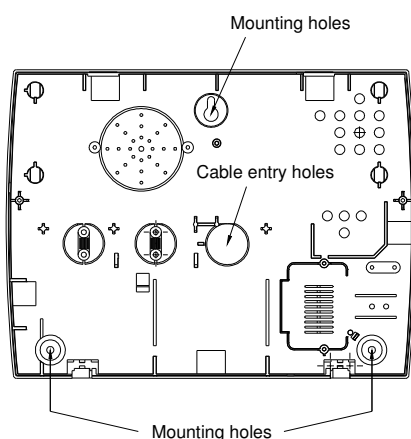

Step 2. Fit the panel to wall with suitable fixings. Ensure the wall surface is flat to prevent base distortion. There are cable entry holes provided in the rear of the base and around the outside edges through the thinned out plastic sections which may be cut away as required.

Step 3. The hole provided adjacent to the mains transformer is a dedicated mains cable entry point.

2.2 - PCB

There are three fuses mounted on the circuit board. All are 20mm anti-surge

- F1 1.6A – to protect the positive (+Ve) line of 12V battery
- F2 1A – to protect the RKP 13V supply
- F3 1A – to protect the Siren (Bell)&Strobe supply

As supplied, wire links are fitted across the Tamper terminal to represent a closed circuit.

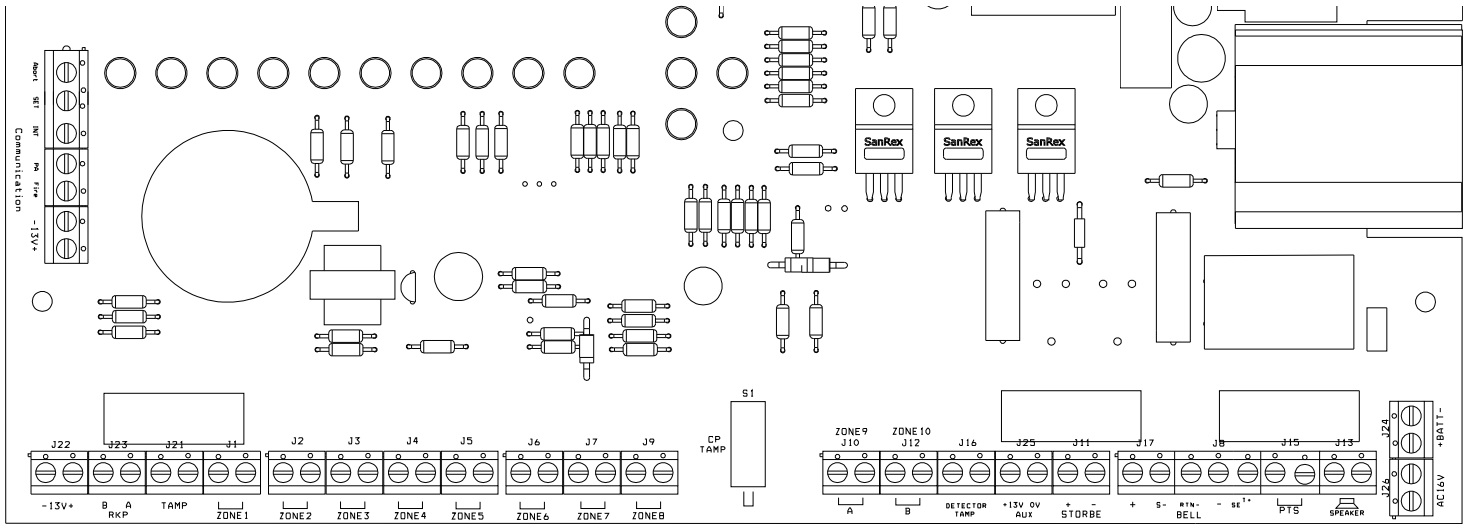

CAUTION: Always power-down the panel when wiring external circuits, to prevent damage to the panel electronics.

Systematically wire and test each circuit:

- Zone, Tamper circuit and PA circuits
- Finish by wiring any additional extension speaker, sounders, external siren (bell)/strobe and the 13V supply.

2.3 - Tamper network

The Tamper circuit is used to protect all cables and detectors in the system from unauthorized access including the panel and RKP covers.

The zone and PA tampers should be series wired and connected to the terminals.

Terminals RTN-&- are for the external siren tamper. The TAMP terminals at the bottom left of the board are for the RKP tampers.

2.4 - Remote Keypads

1). Select LED remote keypad jumper

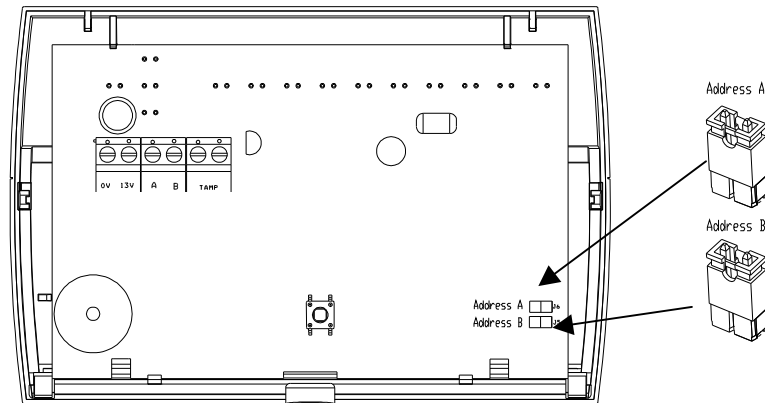

To set the address of the Remote Keypads, please apply the jumper links as follows.

	Keypad 1	Keypad 2	Keypad 3	Keypad 4
Address A	ON	OFF	ON	OFF
Address B	ON	ON	OFF	OFF

2) Wiring diagram

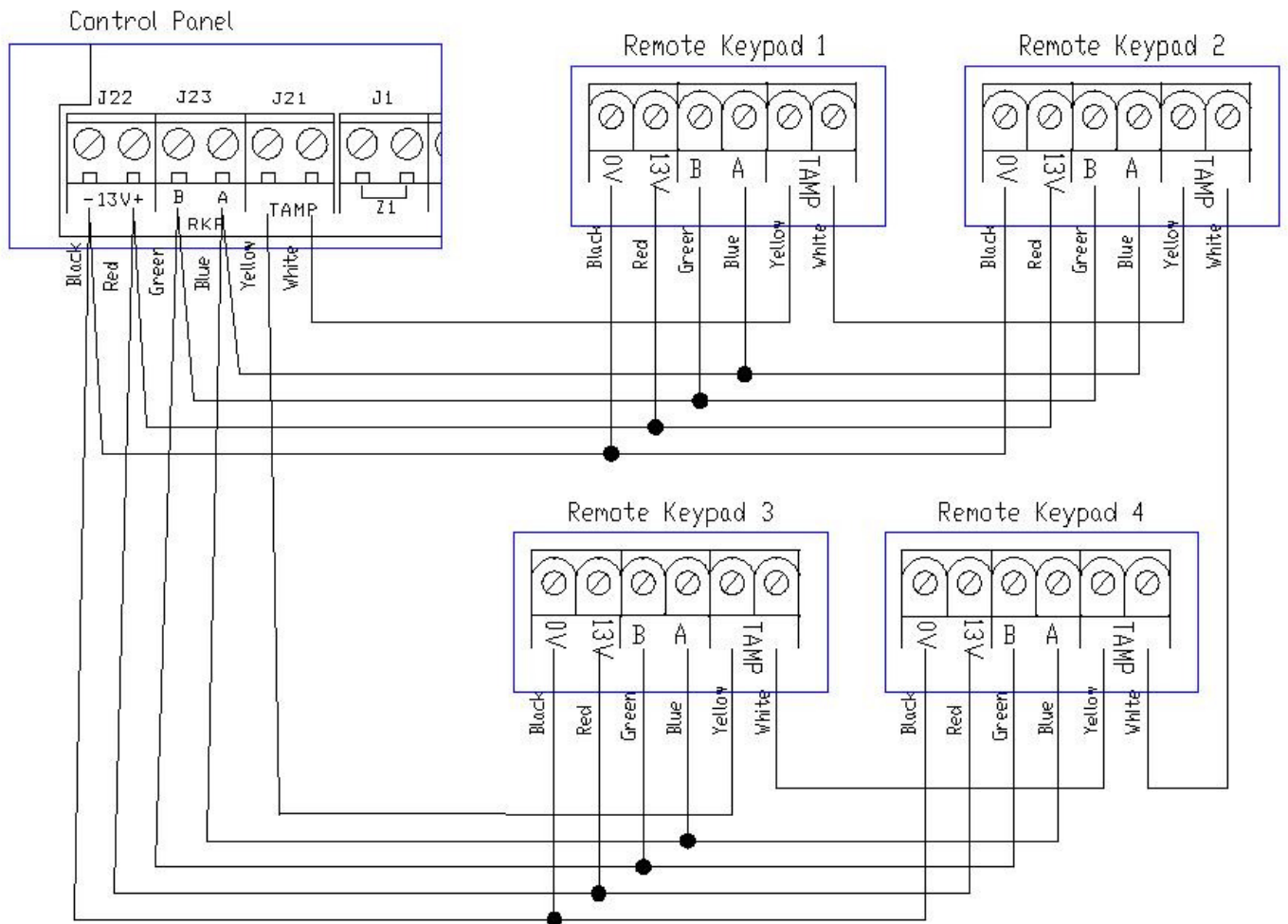

Fitting the Remote Keypad

- a. Separate the RKP base plate from the main assembly by slackening the retaining screw.
- b. Cut away the required thin wall sections around the edges of the base plate for cable entry.
- c. The base plate may be fitted directly to the wall using the screws and wall plugs supplied, if these are not appropriate for the wall the use suitable alternative fixings.
- d. Bring the cables into the base plate and wire to the terminal block on the base plate, see diagram on the previous page.
- e. Refit the RKP main assembly to the base plate by hooking it onto the top holding clips. Check that the wiring does not foul the tamper switch/spring or the PCB support pillar. Rescrew the screw in the bottom of the case.

2.5 - Security Zones

PIR and MS connection to the control panel block diagram.

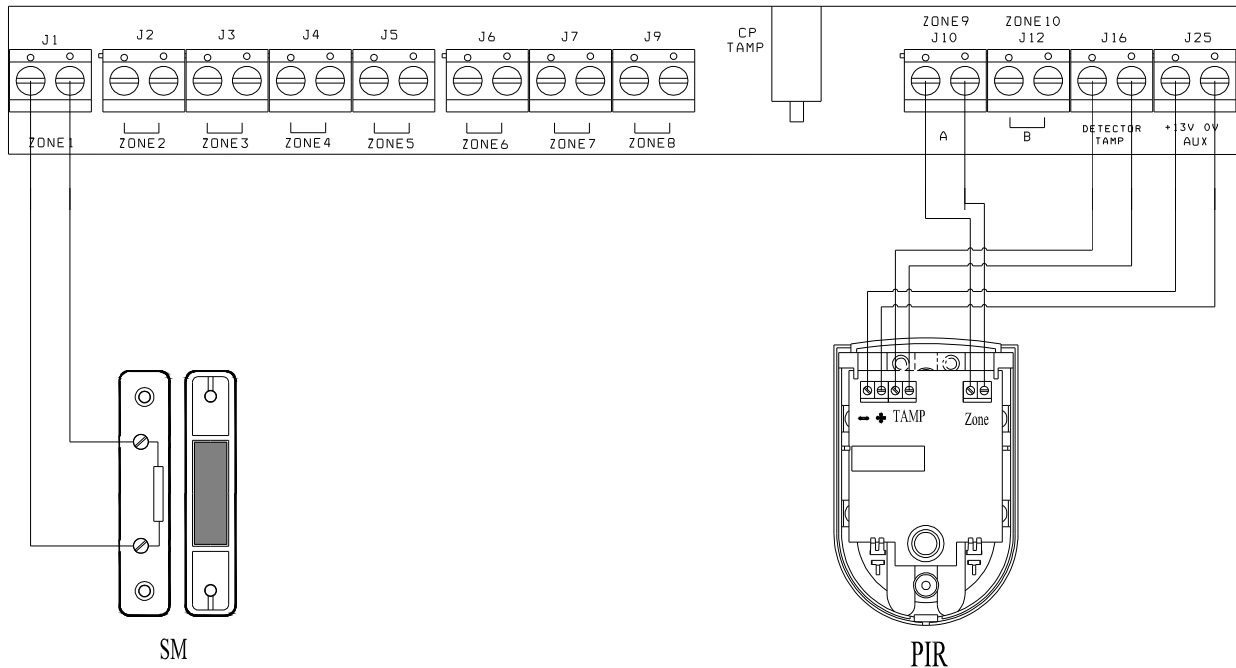

2.6 - Fire Zone Circuit

Any zone may be programmed as a fire zone. This will automatically exclude the zone from programs and normal security applications.

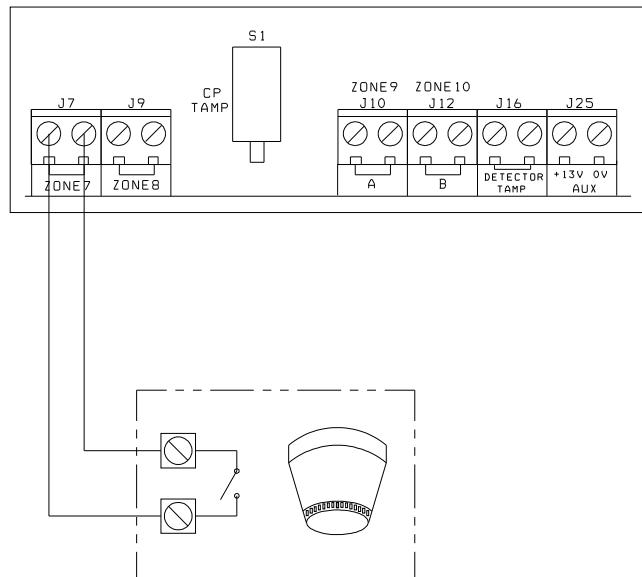

2.7 - Tamper Zone Circuit

Any zone may be programmed as a Tamper zone. Operational in Day and set, the Tamper circuit will cause a full alarm condition when activated.

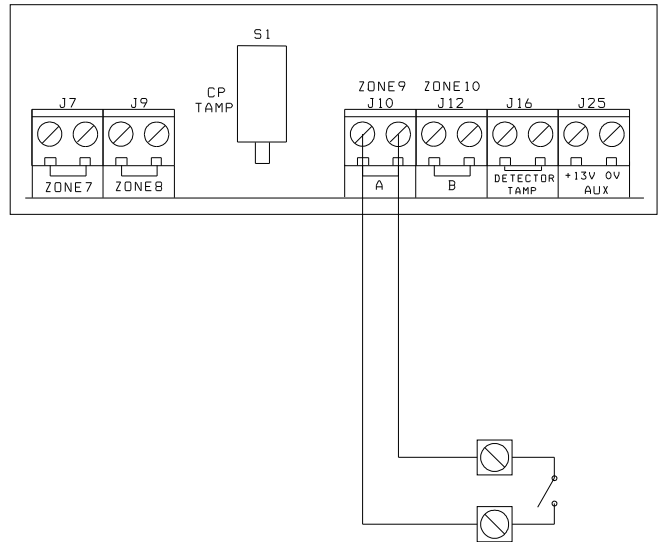

2.8 - PA Zone Circuit

Any quantity of normally closed type personal attack button may be wired in series and then connected to the PA circuit. Operational in Day and set, the PA circuit will cause a full alarm condition when activated. PA is indicated on the control panel or RKP as Attack.

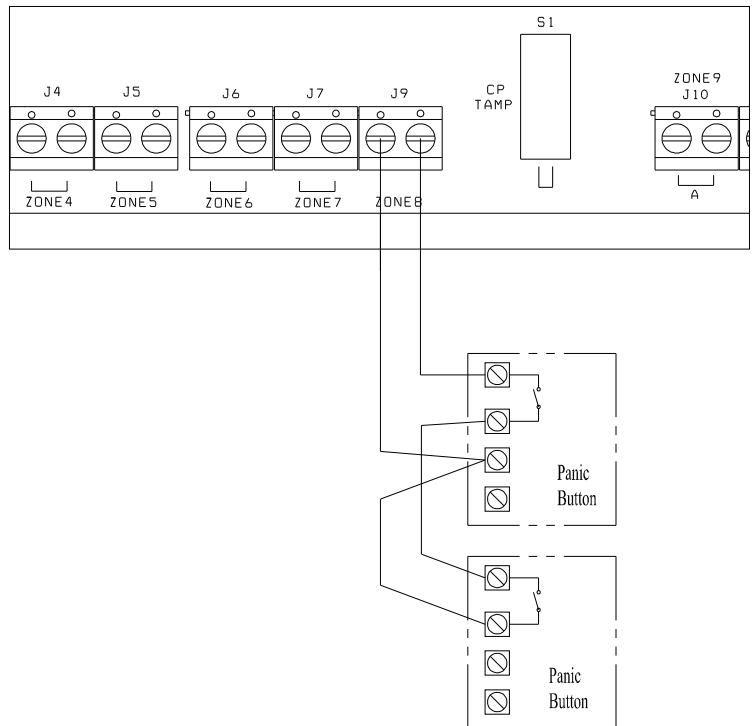

2.9 - Extension speaker

Extension speaker may be connected to the loudspeaker terminals to produce high volume alarm tones and low volume entry/exit/fault tones.

External speaker connects to control panel

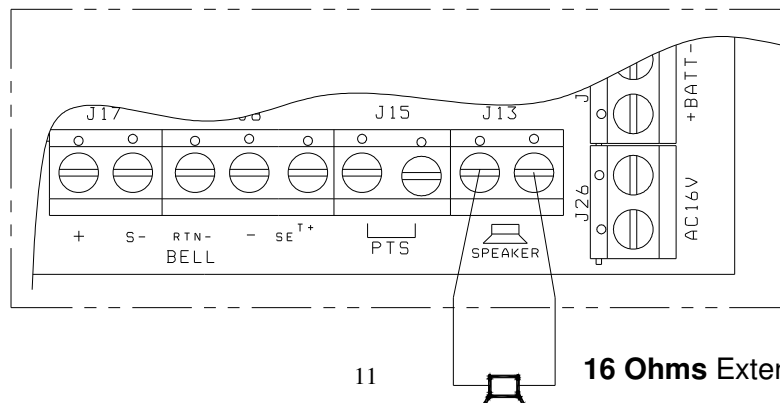

Only one 16 ohms extension speaker may be wired across the speaker terminals. Mounted in convenient positions within the installation the extension speakers will reproduce all of the alarm tones generated by the control panel.

A control marked VOLUME in the center of the board may be used to adjust the low volume entry/exit tones to suit environmental conditions.

2.10 - External siren Output (Bell box)

The external siren (bell box) is usually installed in a high position from where the siren could be seen and heard.

Terminal + S- RTN- - are for connection to the external siren. These terminals provide a power/hold –off supply, sounder trigger and tamper circuit to protect the external siren housing.

The terminals are summarized as follows:

- + +Ve supply (13V)
- S- -Ve Sounder trigger
- RTN- -Ve tamper return
- -Ve supply (0)

Strobe - and strobe +

Where a discrete external siren is used, it should be connected to terminals + & S-. Terminals RTN- & - are then used for tamper protection for the housing.

Bell box wiring to control panel

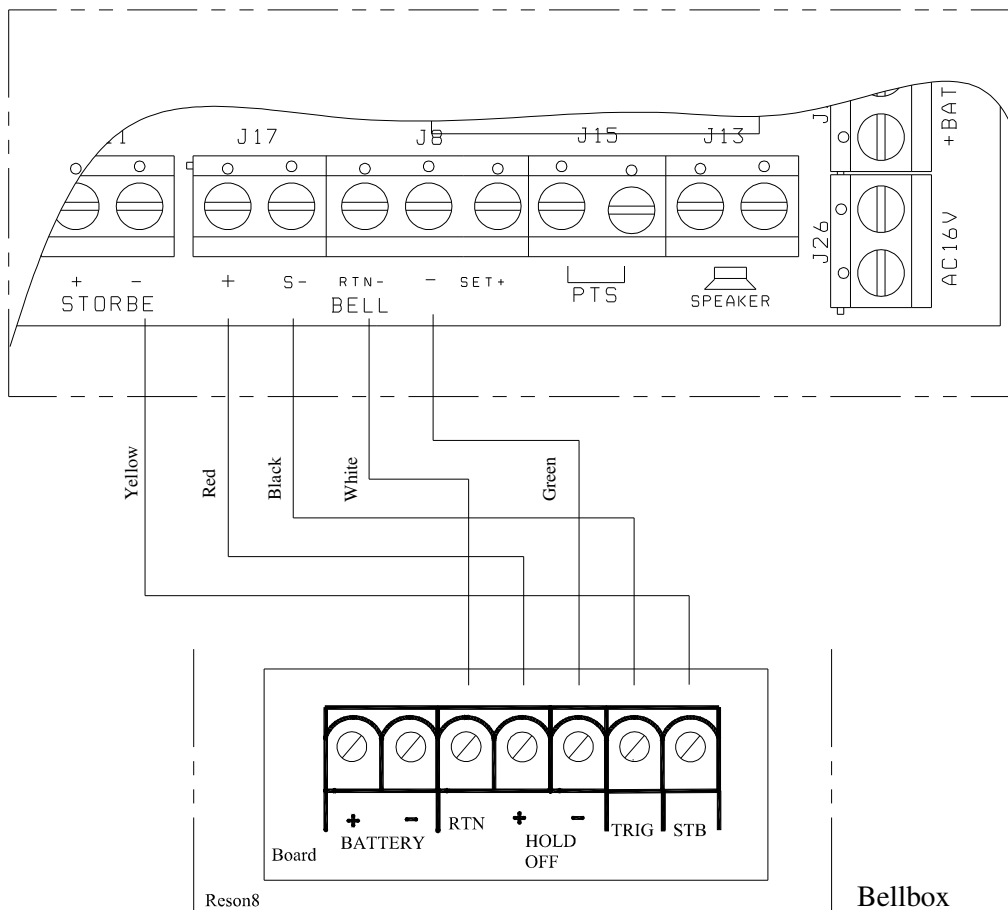

2.10.1 - Vortex II wiring to control panel

Vortex II wiring to control panel

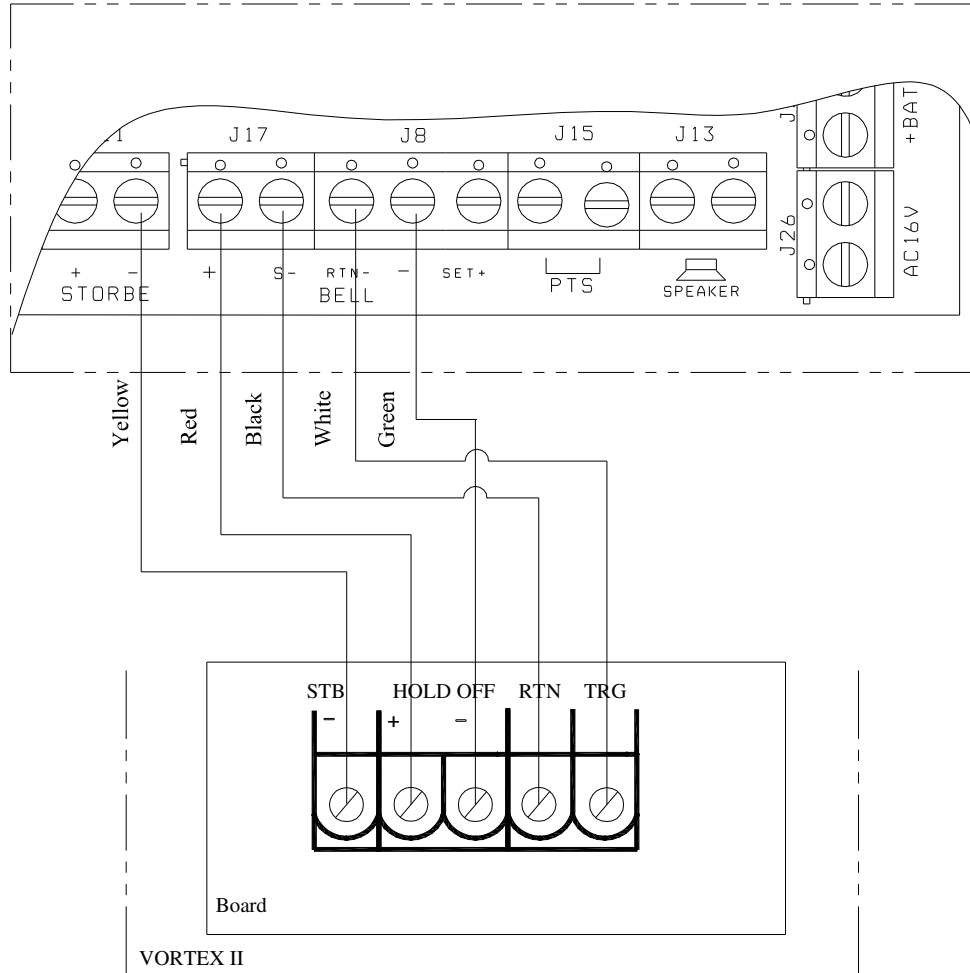

2.10.2 - Solar bell wiring to control panel

Solar bell wiring to control panel

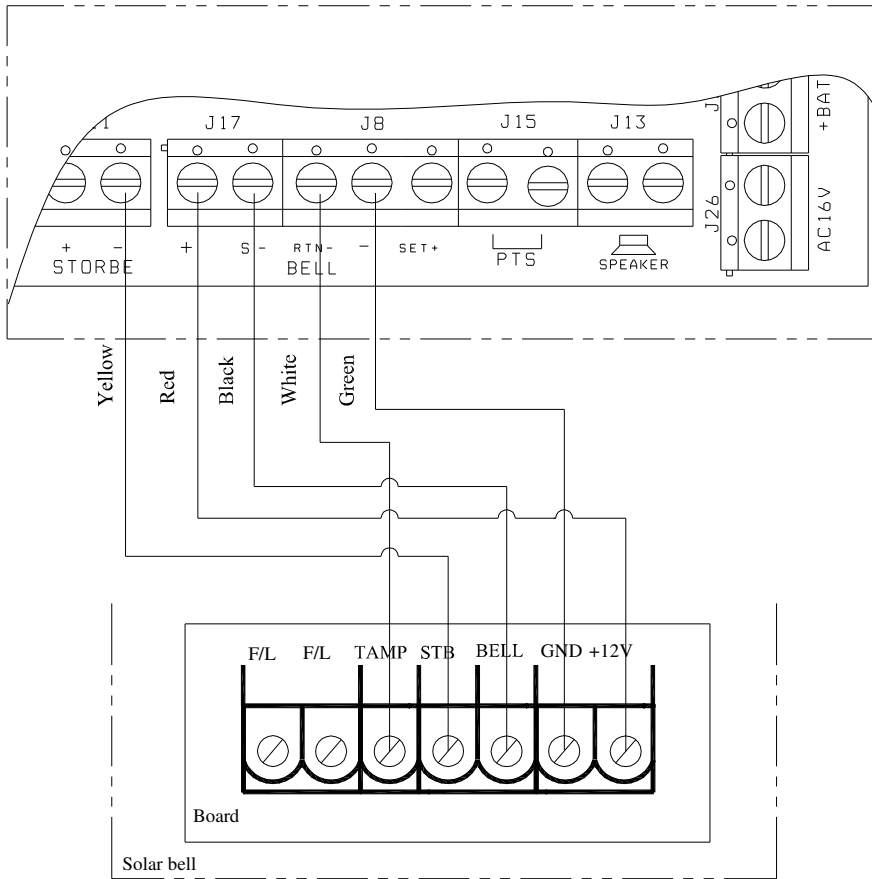

2.10.3 - AD2510 wiring to control panel

AD2510 wiring to control panel

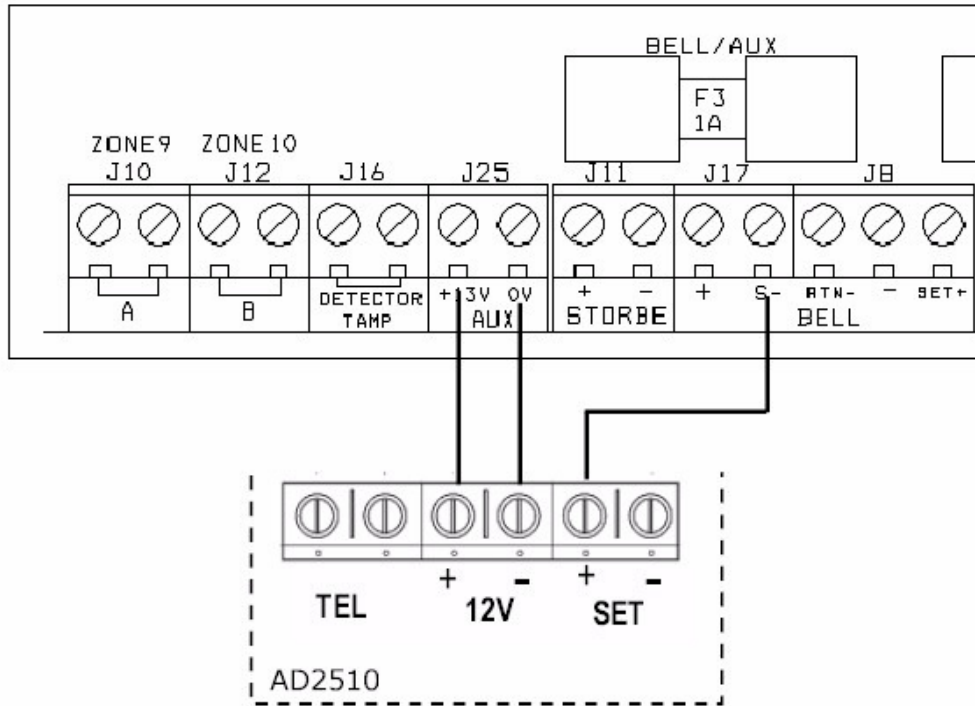

2.11 - 13V Supply Output

The 13V output is to power detectors which require a voltage supply (PIR detector etc). The supply is present at all times and may be used to supply a total of 350mA.

2.12 - Set

The output marked SET becomes positive on correct Set of the system and is removed by entry of a valid user code.

Section 3 - Factory Default Setting

System status

User code 1-2 : Not used
 Holiday code : Not used
 Manager code : 0123
 Engineer code : 9999

Bell time : 14 minutes
 Bell delay time : No delay
 Rearm Count : 3 Rearms

Zone type : Security
 Omit Allowed : Off
 Double Knock : Off
 Chime : Off

System flag

Silent PA : Off
 RKP PA : On
 Engineer Reset : Off
 PA user Reset : On
 Fire user Reset : On
 Bell in Fire : On
 Disable Bell Tamper : Off
 Lock Engineer Code : Off
 Auto walk test exit : Off

Key Switch/PTS : Off
 PTS as Door Bell : Off
 Strobe on SET : On
 Single key SET : Off
 EOLR zone : Off
 EN compliant : Off



SET mode

Full mode:
 Zone 1 : Timed
 Zone 2 : Inhibited
 Zone 3-10 : Immediate
 Exit Mode : Timed Exit
 Exit Time : 45 sec
 Entry Time : 45 sec

Part 1 mode:
 Zone 1,2 : Timed
 Zone 3-8 : Immediate
 Zone 9-10 : Not Used
 Exit Mode : Timed Exit
 Exit Time : 45 sec
 Entry Time : 45 sec

Part 2 mode : Disabled

Indications on the system

Indications	
LED steady on indication	✱
LED flashing indication	⬤
LED off	○
Internal Sound	
External Device: Strobe	
External Siren: Bell	

Defaulting Manager code and Engineer code

- Power off the alarm unit
- Connect a lead wire between terminal [RTN-] and [SET+]
- Power on the alarm unit. Two beep sound are heard and All codes are reset
- Clear the siren by keying in the default Manager code
- Remove the lead wire and return to Day mode by pressing

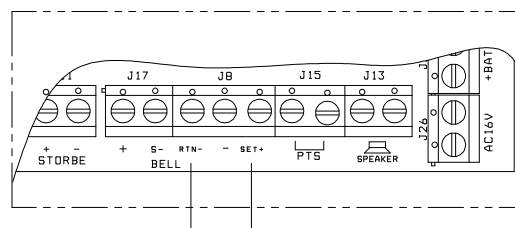

<Reset> button

Section 4 - Mains Connection

The mains power should be connected using a 3 core cable of not less than 1mm sq. from a fused spur to the mains connector inside the control panel.

NOTE: The mains supply must be connected by a technically competent person and according to current IEE regulations.

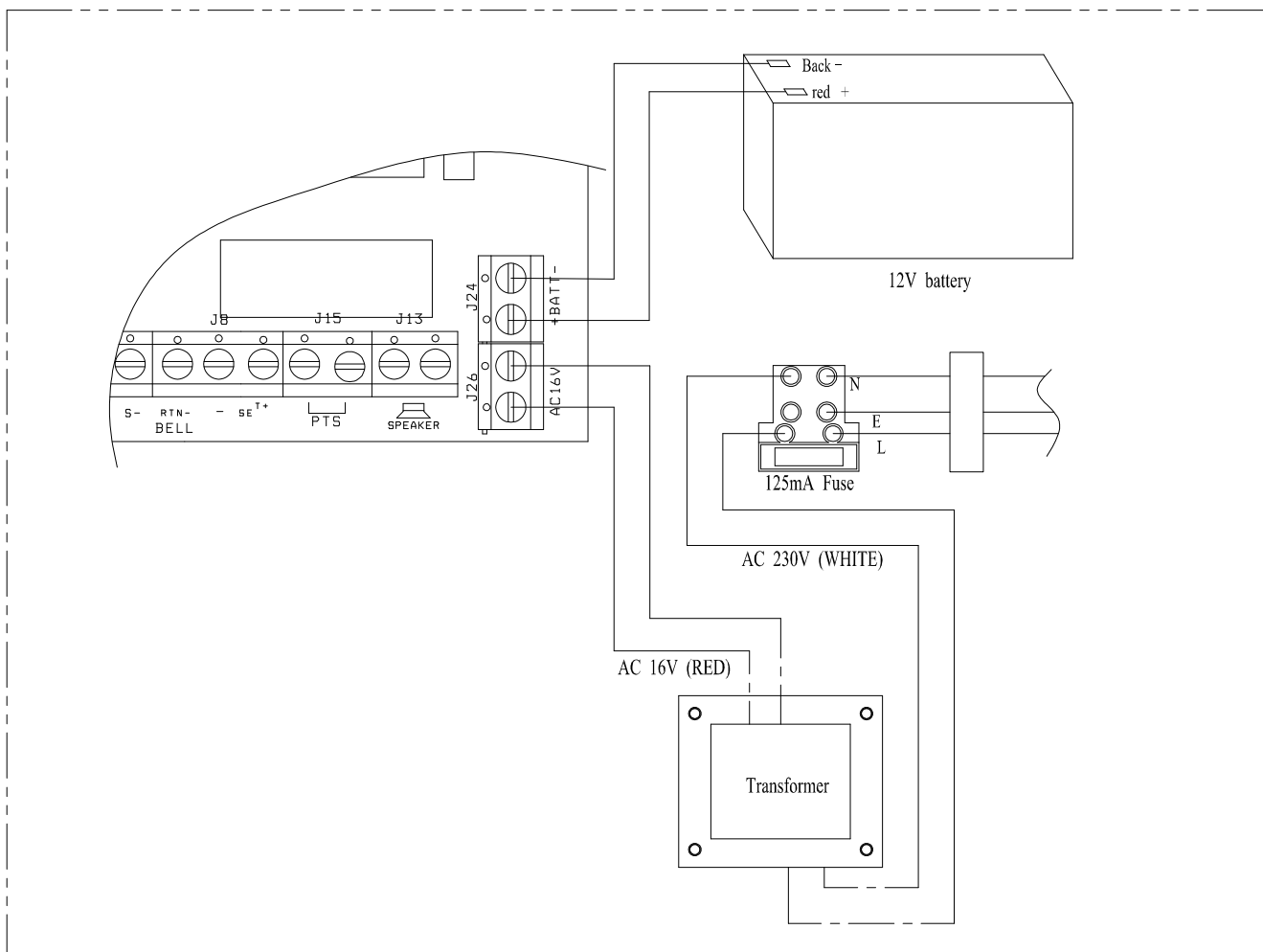

CAUTION: To avoid the risk of electrical shock you must always totally isolate the mains supply before opening the control panel cover(s).

Mains input fuse rating: 125mA, 250V type.

On connecting the mains supply to the panel the power indicator is lit. * Power

Testing the System

Complete the wiring of the system and then:

- Fully test the system and ensure it is fault free.
- Fully program the system.
- Fill in the installation log at the back of the manual and retain it for future reference.
- Finally explain the operation of the system to the end user.

Section 5 - First Power Up

- a. Check that the factory fitted links are connected to terminals TAMP and RTN-& -.
- b. Fit the battery wires to the BATT terminals on the Board, Red to + and Black to -.

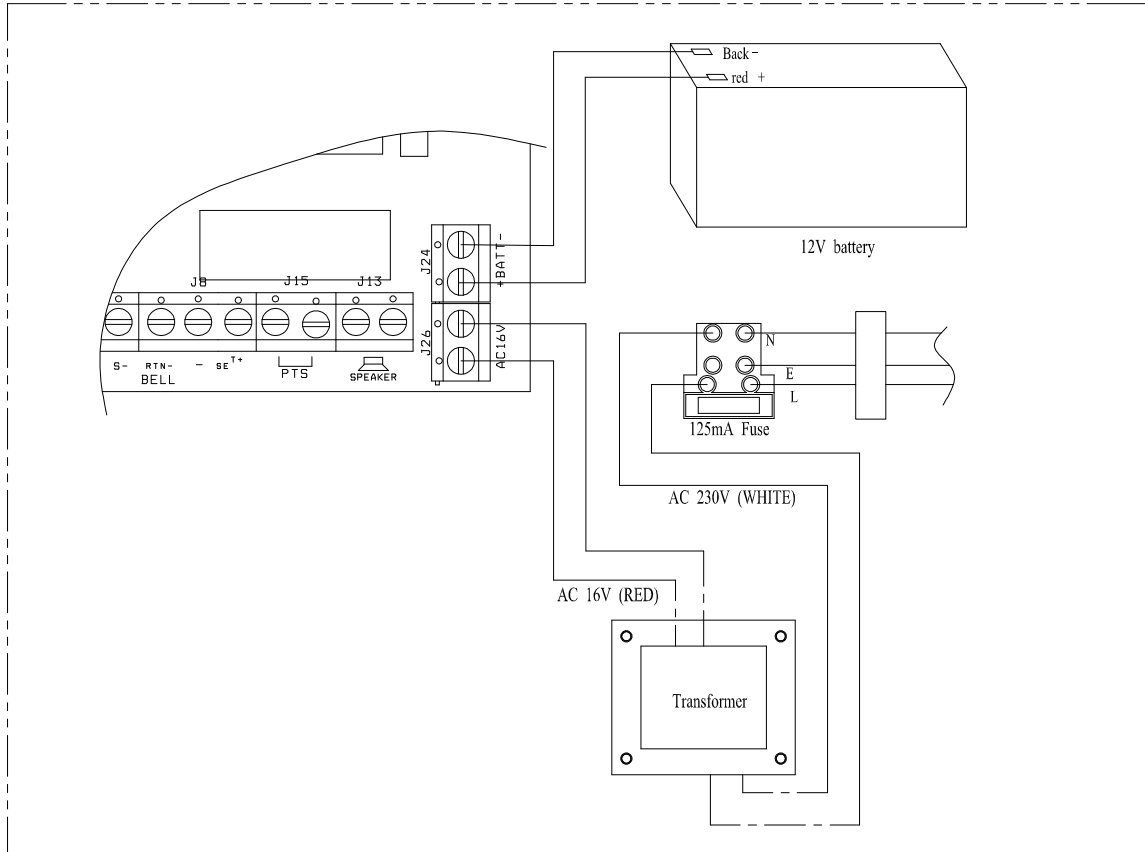

- c. On connecting the battery the system will now go into alarm condition and Day led is indication.

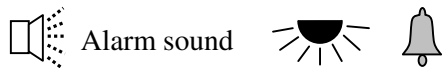
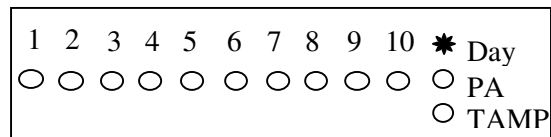

- d. Fit the cover to hold down the tamper spring at the bottom right-hand of the board.
- e. Enter User code / Manager code (0)(1)(2)(3) (factory set code).

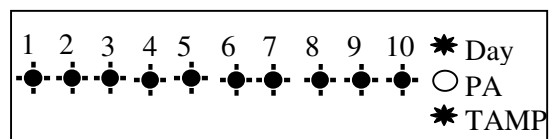

f. Press  to return to Day mode.

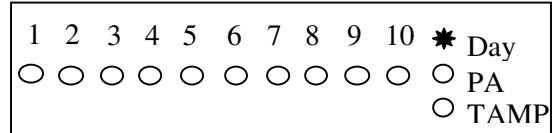

g. Immediately enter the engineer code 9-9-9-9 factory default setting. Or go to page 16 how to enter program mode. If authorized by manager code.

h. The system will go into Engineer program mode. Under engineer mode, you can program.

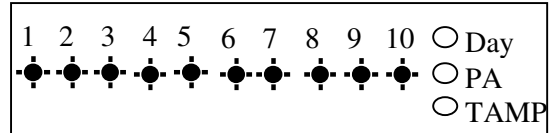

Engineer Program Mode

The control panel may be programmed to suit a wide variety of installations.

Once the engineer program mode has been accessed, each configuration may be changed in any order.

Before entering engineer program mode the system should be in the Day mode, with the Day and PWR indicators lit.

Section 6 – How to Set up the system

The full menu structure for the panel can only be accessed while in Engineer Program Mode. The structure is shown in the following table:

MENU OPTIONS	
1 Setup Programs	5 Setup System
2 Setup Zones Name and Type	6 Misc Menu
3 Setup Zones Attrib	7 View alarm log
4 Setup Codes	8 Test System

6.1 - How to enter Engineer Program Mode

You should require the manager to authorize Engineer access. It is accessed directly form Day mode via the Engineer code.

To operate the “Enter Engineer operation mode” as follow:

- Enter Manager program mode.

- Press **PROG** **0** **1** **2** **3**

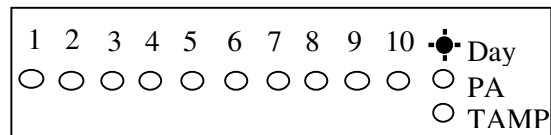

- Press **3** to authorize Engineer access.

Then Engineer can access program mode for 1 hours.

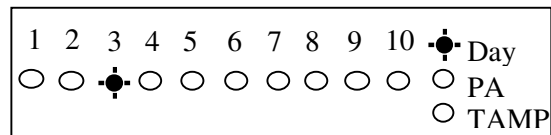

- Press to **RESET** **RESET** leave the current menu.

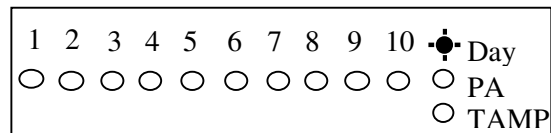

- Input 4-digit Engineer code **9** **9** **9** **9** to go to engineer operation window.

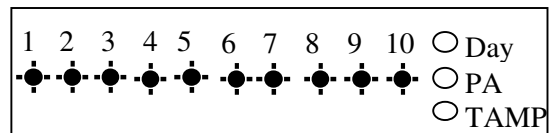

6.2 - Setup Programs

The panel has three programs: **1 = Program Full, 2 = Program Part1, 3 = Program Part2.**
 Each program can set all parameters independent, these are **1 = Zone Function, 2 = Exit Mode, 3 = Exit Time, 4 = Entry Time.**
 Zones can also be assigned different functions in different programs. Refer to the following diagram for the programming structure.

6.2.1 - How to go into Full mode Setting

- Under Engineer mode.
- Press **1** to Select **Setup Programs**.
- Press **SET** to accept and go into **Program Full**.

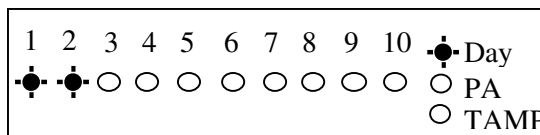
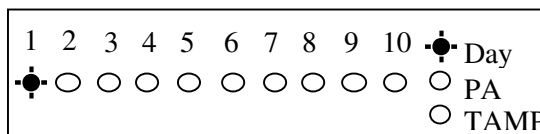

6.2.2 - How to go into Part 1 mode Setting

- Under Engineer mode.
- Press **1** to Select **Setup Programs**.
- Press **OMT** to accept and go into **Program Part 1**.

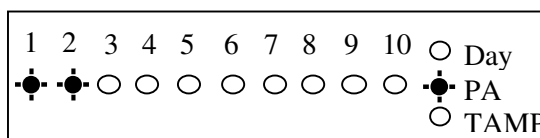
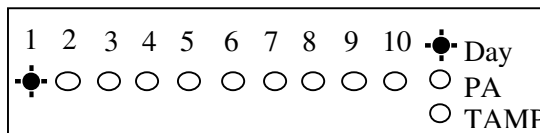

6.2.3 - How to go into Part 2 mode Setting

- Under Engineer mode.
- Press **1** to Select **Setup Programs**.
- Press **🎵** to accept and go into **Program Part 2**.

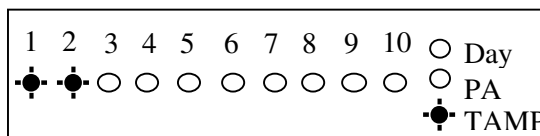
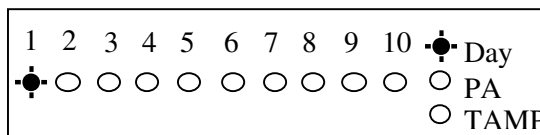

6.2.4 - How to set zone function

In **Zone Function**, Security type zones can be assigned different functions. These are

1= Immediate Zone, 2 = Timed Zone, 3 = Inhibited Zone.

Immediate Zone:

Use this function when the zone is not part of an entry/exit route. When the system is **SET**, activation of an immediate zone will cause a full alarm condition.

Timed Zone:

A timed zone would be used to protect an entry/exit route. Opening the door or triggering the sensor in this type of zone when the system is **SET** will start the entry timer.

Inhibited Zone:

A time-inhibited zone operates as an immediate zone unless a timed zone has been operated and a timer started. Such a zone should be utilized to allow passage between the entry/exit door and the control panel or key pad when there are detectors present.

Set zone Immediate function

Under Engineer Menu/Setup Program, the program Full mode is chosen. LED 1 and LED 2 is flashing.

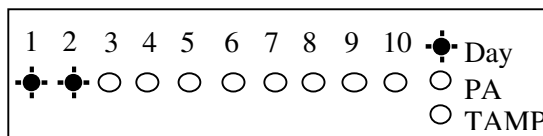

- Press **1** to program Immediate Zone.
LED 3~10 ON indicate selected immediate zones.
Default settings are on.

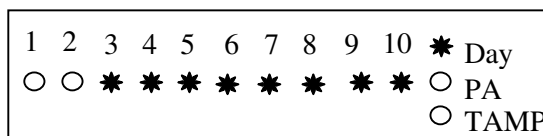

- To edit the other zones press Zone number (1~10). If selected, LED is on.
If you select Zone 2 to be immediate zone,

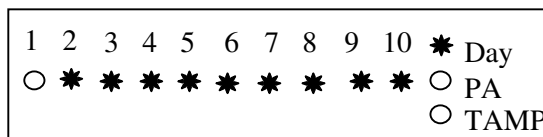

- Press **SET** to accept the change
Or press **RESET** to cancel.

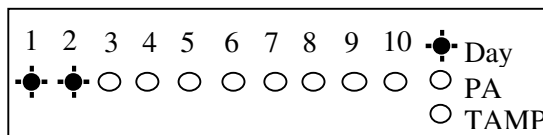

Set zone Timed function

Under Engineer Menu/Setup Program, the program Full mode is chosen. LED 1 and LED 2 is flashing.

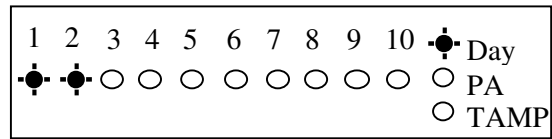

- Press **2** to program Timed Zone.
LED 1 ON indicate selected Timed zone.

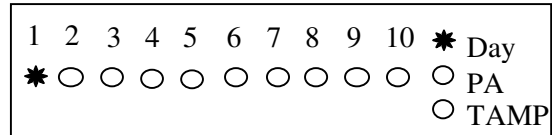

Default settings are on.

- To edit the other zones press Zone number (1~10). If selected, LED is on.
If you select Zone 4 to be timed zone,

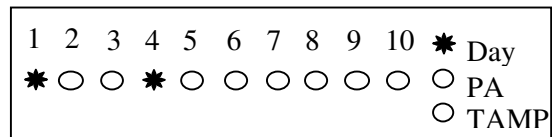

- Press **SET** to accept the change
Or press **RESET** to cancel.

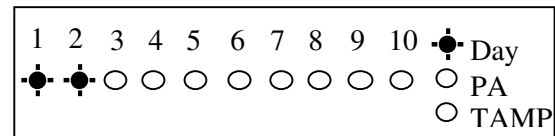

Set zone Inhibited function

Under Engineer Menu/Setup Program, the program Full mode is chosen. LED 1 and LED 2 is flashing.

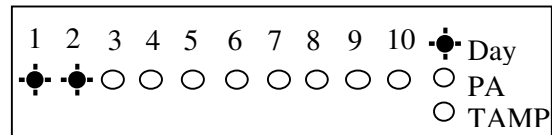

- Press **3** to program Inhibited Zone.
LED 2 ON indicate selected inhibited zones.
Default settings are on.

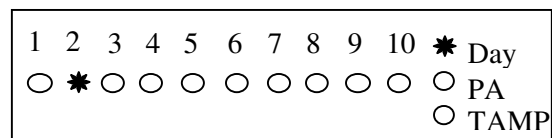

- To edit the other zones press Zone number (1~10). If selected, LED is on.
If select Zone 3 to be inhibited zone,
Then press **2** and press **3**

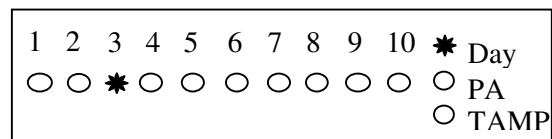

- Press **SET** to accept the change
Or press **RESET** to cancel.

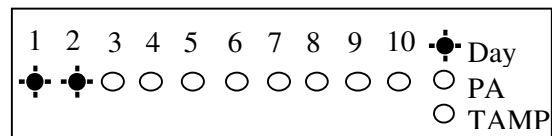

6.2.5 - How to set Exit mode function

There are five selections for **Exit Mode** in all, mode: **1 = Timed Exit, 2 = Final Door, 3 = Silent Exit, 4 = Terminated, 0 = Disabled.**

Timed Exit:

A timed program will set once the exit timer has expired and all zones are clear.

Final Door:

A final door program will set 5 seconds after the final door has been opened and closed.

Silent Exit:

This operates exactly the same as **Timed Exit** but completely silent without internal sounder signal.

Terminated:

A terminated program will set once the PTS terminal has been trigger.

Disabled:

A disabled program is not available for use and cannot be selected and setting time.

Under Engineer Menu/Setup Program, the program Full mode is chosen. LED 1 and LED 2 are flashing.

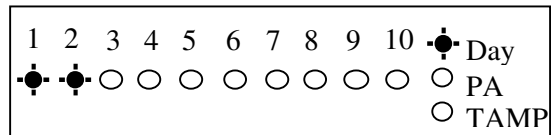

- Press **4** to program Timed Exit.
LED 1 ON indicates system selected: Timed

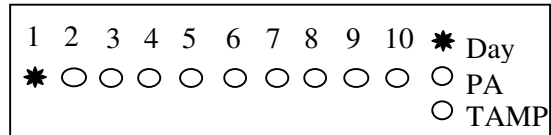

- Change exit mode to Silent Exit.
Press **3** to select silent exit.

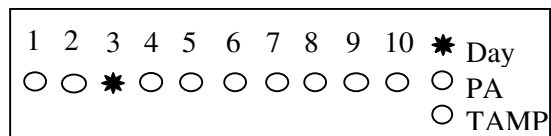

- Press **SET** to accept the change
Or press **RESET** to cancel. Press **RESET** to return to Engineer mode.

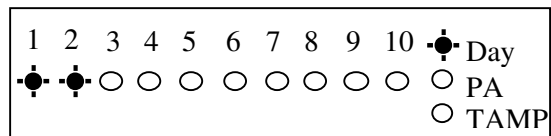

6.2.6 - How to set Exit time function

This is the time allowed to leave the premises via the exit route before the system sets. The programmable range is 00-99 seconds.

If the **Exit Time** is interrupted with the last 10 seconds, then the **Exit Time** will restart at 10 seconds after the interruption has cleared.

The default is 45 seconds.

Under Engineer Menu/Setup Program, the program Full mode is chosen. LED 1 and LED 2 are flashing.

- Press **5** to select Exit time item. Z1, Z2 LED light indicate you input 2 digit Number.
- Set the exit time of full arm mode 20 seconds. Then Press **2** digit number, Z1 LED off .
- Then Press **0** digit number, Z2 LED off . PA and TAMP LED flashing indicate you accept or cancel.

- Press **SET** to accept the change. Or press **RESET** to cancel. Press **RESET** to return to Engineer mode.

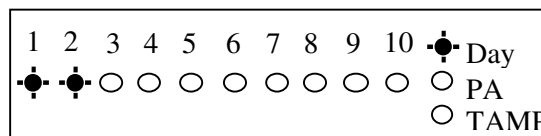
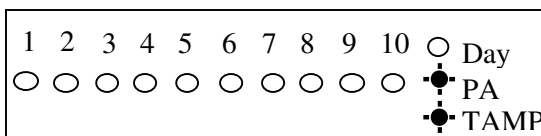
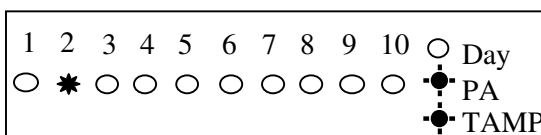
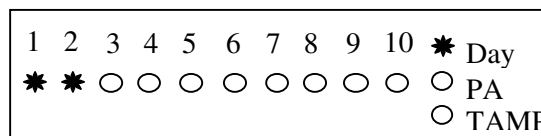
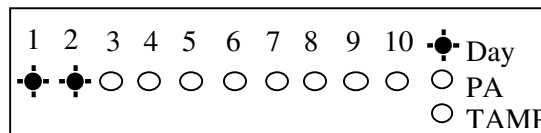

6.2.7 - How to set Entry time function

This is the time allowed to enter the premises via the entry route and unset the system. The programmable range is 00-99 seconds. The default is 45 seconds.

Under Engineer Menu/Setup Program, the program Full mode is chosen. LED 1 and LED 2 are flashing.

- Press **6** to select Entry time item. Z1, Z2 LED light indicate you input 2 digit Number.
- Set the exit time of full arm mode 20 seconds. Then Press **2** digit number, Z1 LED off .
- Then Press **0** digit number, Z2 LED off . PA and TAMP LED flashing indicate you Accept or cancel.

- Press **SET** to accept the change. Or press to cancel. Press **RESET** to return to Engineer mode.

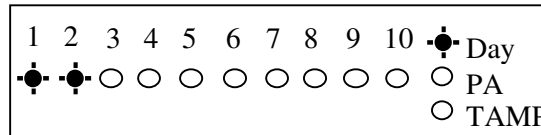
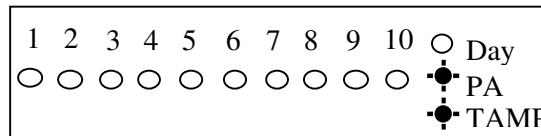
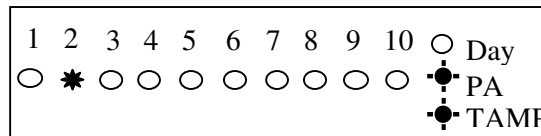
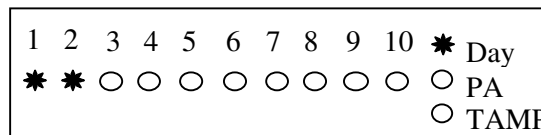
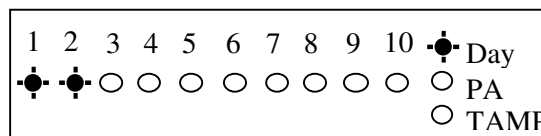

6.3 - Setup Zones Type

6.3.1 - How to set Zone Type

There are six types for Zone: **1 = Security**, **2 = PA**, **3 = Fire**, **4 = Tamper/24Hr**, **5 = Door Bell**, **0 = Not Used**.

Security:

The system comes supplied with service links fitted to the zone terminals to simulate a closed circuit. As each zone is connected these links should be removed. All zones are fully programmable. This is 12hr operates when panel is set.

PA:

A Zone may be programmed for audible PA and should be wire in series. This is 24hr operates if panel is set or unset.

Door Bell:

This feature can be programmed into any Zone. A doorbell will not operate whilst the entry/exit timers have started, when the system is in full alarm condition or whilst in programming mode.

Fire:

If you choose to utilize a zone as a fire zone then no other detectors may be wired into this zone. Therefore a zone cannot be both fire and intruder. This is 24hr operates when panel is set or unset.

Tamper/24Hr: Provides 24 hour monitoring when set or unset.

Not used

A zone may be programmed as Not used, and then is ignored by the panel.

To operate the Setup Zone type as follow.
e.g. Change zone 5 type to Tamper/24Hr.

- Under Engineer mode.

- Press **2** to select set up Zone Type.

• Press a number button to select Zone to be configured.

Then press **5** to select zone 5, Zone type of Zone 5 is Security.

- Press **4** to select Tamper/24Hr

- Press **SET** to accept the change. Or press **RESET** to cancel. Press **RESET** to return to Engineer mode.

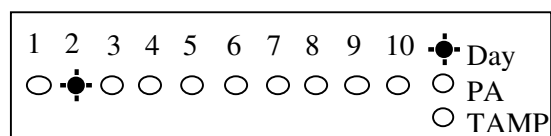
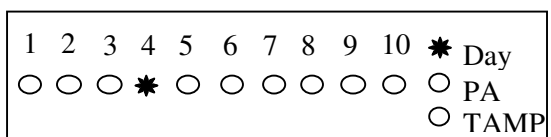
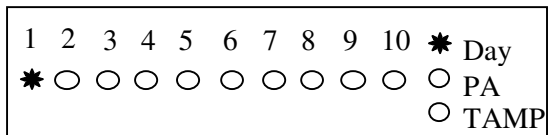
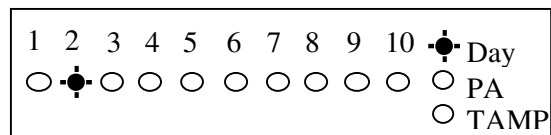
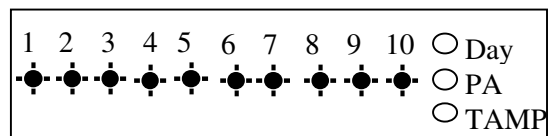

6.4 - Setup Zones Attributes

There are three attributes for Zone: 1 = Omit Allowed, 2 = Double Knock, 3 = Chime. You can set it ON or OFF.

Omit Allowed:

When a Zone is programmed as Omit Allowed, the panel allows the Zone to be Omitted for one set period by the user when setting the system.

Note: The zone must to be set to security then it can be set omit allowed.

Double Knock:

Double knock programming is used when zones are likely to create false activations.

Double knock requires two activations within 10 minutes of the same Zone or a Zone left open for 10 seconds.

Chime:

If a Security Zone is programmed as Chime, you can hear special tone when it is triggered in DAY mode.

Note: The zone must to be set to security then it can be set Chime.

To operate the Setup Zone attributes as follow.

e.g. Set zone 2 to have Omit Allowed, Double Knock and Chime attributes (set ON).

Omit Allowed

- Under Engineer mode
- Press (3) to select Zone Attributes menu.

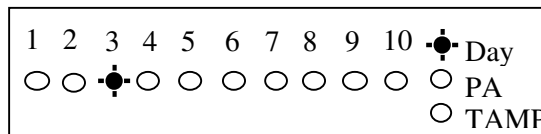

- Press zone No. to select zone (0~9).
If you set Zone 1 attribute is omit allowed.

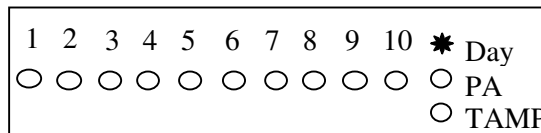

- Press (1) to select Omit Allowed.

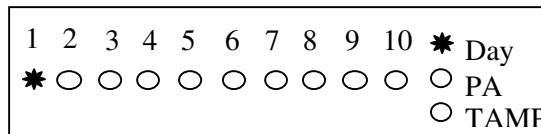

- Press (SET) to accept the change
Or press (RESET) to cancel.

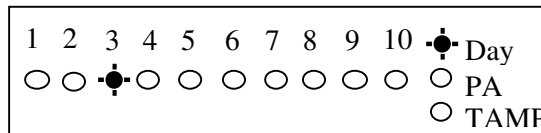

Double Knock

- Under Engineer mode.
- Press (3) to select Zone Attributes menu.
- Press zone No. to select zone (0~9)
If you set Zone 4 attribute is double knock.

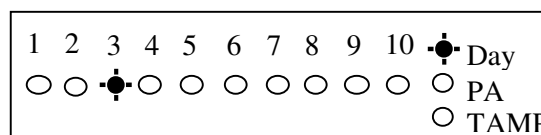

- Press (2) to select double knock.

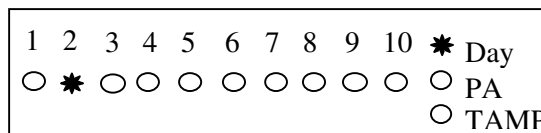

- Press **SET** to accept the change or press **RESET** to cancel.

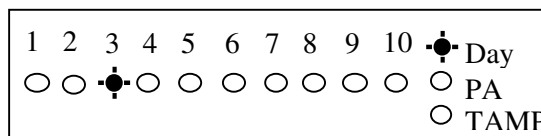

Chime

- Under Engineer mode
- Press **3** to select Zone Attributes menu.

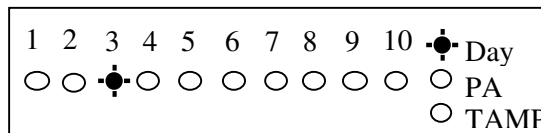

- Press zone No. to select zone (0~9).
If you set Zone 5 attribute is Chime.

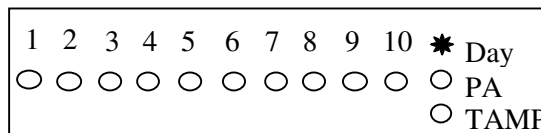

- Press **3** to select Chime.

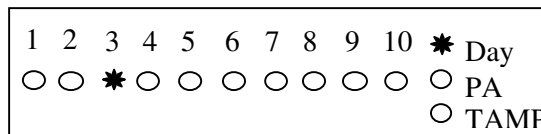

- Press **SET** to accept the change. Or press **RESET** to cancel. Press **RESET** to Return to engineer mode.

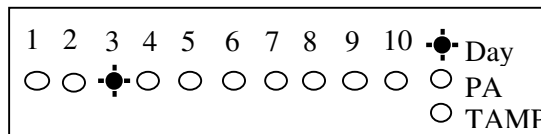

6.5 - Setup Codes

The access codes ensure that only authorized users can operate the system. All are 4-digit and can be set to any number from 0000 to 9999

1 = user 1, 2 = user 2, 3 =Holiday, 4=Engineer,

User 1 – User 2 codes:

The user 1 –user 2 codes have the same operation for testing and Setting and Unsetting, changing their own code.

Holiday code:

The purpose of this code is to allow access to the property whilst the manager is absent. The Holiday access code is programmed by the Manager and is only valid until the manager use's the system. At this point the Holiday code becomes invalid and is no longer accepted by the control panel.

Engineer code:

Access to the Engineer program mode to allow the system to be programmed. If configured the Engineer's code can be used to reset the system after an alarm.

NOTE: Entering an invalid user code 4 times will operate the code tamper and lock you out. After another 5 times invalid user code , a full alarm condition will be generated.

6.5.1 - How to set up/change User Code

Under Engineer Menu.

- Press **4** to select Setup User codes.

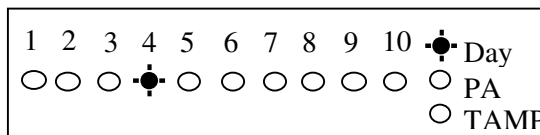

- Press **1** to change User 1.

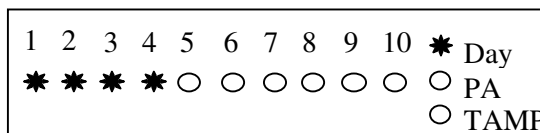

- Enter the new user 1 code (4 digits)
? **?** **?** **?** New code

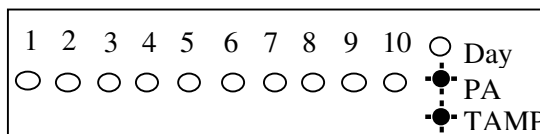

- Press **SET** key to save. If the 4-digit is the same as old, the error tone will be generated.
- Press **RESET** key will cancel and return.

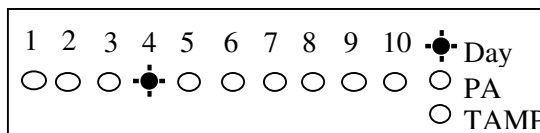

6.5.2 - How to delete User Code

Under Engineer Menu.

- Press **4** to select Setup User codes.

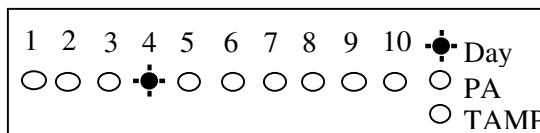

- Press **1** to change User 1.

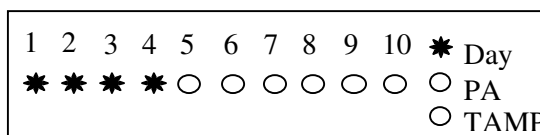

- Press **OMI** key to delete user 1 code.

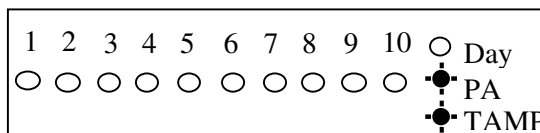

- Press **SET** to accept .
 Or press **RESET** to cancel. Press **RESET** to
 Return to engineer mode.

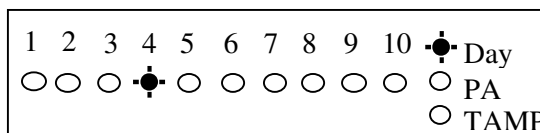

6.6 - Setup system

The Setup system contains five parts. They are listed as follow:

1 = Flags1, 2 = Flags2, 3 = Bell Time, 4 = Rearm count, 5 = Bell delay time

6.6.1 - How to Setup System Flags

The System Flags are divided into Flags1, 2.

Flag1 – Options

There are eight options under Flag1 which are described below:

2=RKP PA, 3=Engineer Reset, 4=PA user Reset, 5=Fire user Reset, 6=Bell in Fire,

7=Disable Bell Tamper, 8=lock Engineer Code, 9=Exit Walk Test

RKP PA

When this flag is set to ON, the keypad's PA function is enabled.

Engineer Reset

When this flag is set to ON, an engineer code must be entered to reset the system after Tamper, PA or Fire alarm. When the flag is set to OFF the system can be reset by the user.

PA user Reset

When this flag is set to ON, it permits the user to reset the system after a PA alarm, by pressing user code. The user can reset the system even if the **Engineer Reset** flag is set to ON.

Fire user Reset

When this flag is set to ON, it permits user to reset the system after a Fire alarm by pressing user code. The user can reset the system even if the **Engineer Reset** flag is set to ON.

Bell in Fire

When this flag is set to ON, the external siren Bell box will sound On/two seconds off /two seconds during the fire alarm.

Disable Bell Tamper

When this flag is set to ON, when the Bell Tamper is trigger in FULL, Part1, Part2 mode the alarm system will not process it.

Lock Engineer Code

When this flag is set to ON, System cannot change the engineer code in manager menu.

Exit Walk Test

When this flag is set to ON, it will automatically return to next option after 20 minutes.

- Under Engineer mode
- Press **5** to select Setup system.

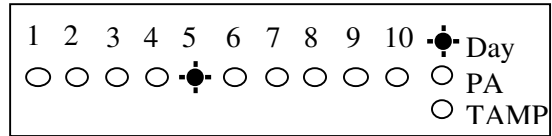

- Press **1** to select system flag item.

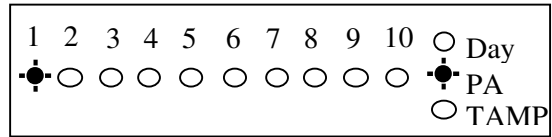

- Press **1** to select system flag 1 option.
Default settings are on.

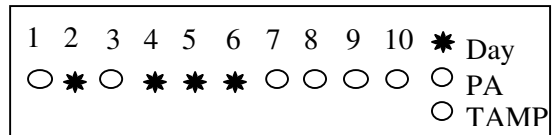

- For example, add Engineer Reset and Walk Test Auto-exit enable.
Press **3** and **9** to select.

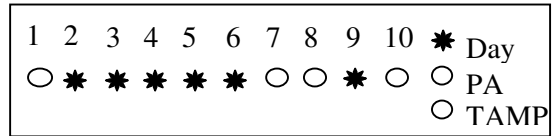

- And cancel PA User Reset,
Press **4** to disable, the corresponding LED OFF.

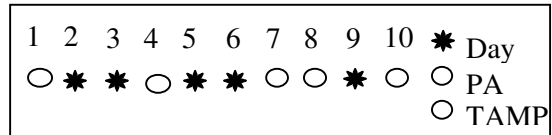

- Press **SET** to accept the change. Or press **RESET** to cancel. Press **RESET** to return to Engineer mode.

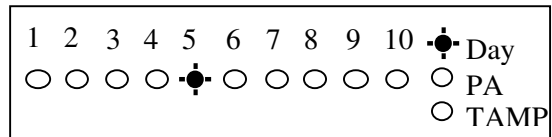

Flag2 – Options

There are six options under Flag2 which are described below:

1=Key switch, 2=Doorbell, 3=Strobe on Set, 4=Single key Set, 5=EN Compliant, 6=EOLR Zone

PTS as Key switch

When this flag is set to ON, this enables the system to be SET and UNSET with the use of a key switch in PTS terminal. If the panel needs to be reset then a manager/user code must be entered.

PTS as Doorbell

When this flag is set to ON, Keyswitch = OFF, the PTS terminal is programmed to a doorbell, if the Keyswitch = ON, the PTS terminal is used as Keyswitch.

Strobe on Set

When this flag is set to ON, the external strobe will stay on for five seconds once the panel has set.

Single key Set

When this flag is set to ON, it allows the panel to be set Full mode by pressing the [Set] button, set Part 1 mode by pressing [OMIT] key, set Part 2 mode by pressing [🎵] key. A code entry is not required. However, a 4-digit code is required to Unset the panel.

EN Compliant

When this flag is set to ON, the alarm system has Battery Monitoring function.

EOLR Zone

When this flag is set to ON, the alarm system goes to EOLR mode. Each detector must have a 2k2 resistor connected across its alarm contacts. In addition, a 2k2 resistor must be connected across the end of the Zone wiring, as shown in the following diagram. Note the PIR detectors usually have a “spare” terminal for this purpose.

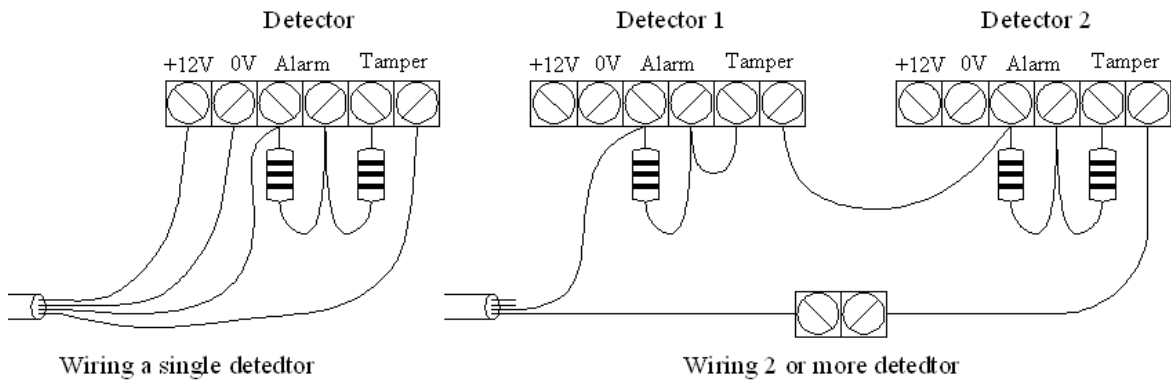

To operate Flag 2 as follow.

- Under Engineer mode.
- Press **5** to select Setup system.

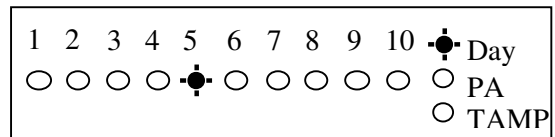

- Press **1** to select system flag item.

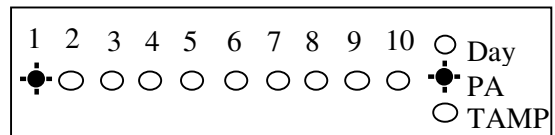

- Press **2** to select system flag 2 option.
Default settings are on.

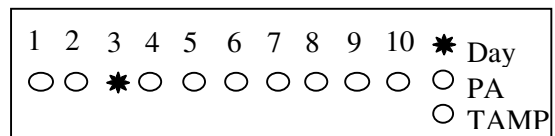

- For example, add EN Compliant flag.
Press **5** to select.

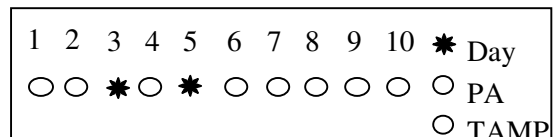

- Press **SET** to accept the change
Or press **RESET** to cancel. Press **RESET** **RESET**
To return to Engineer mode.

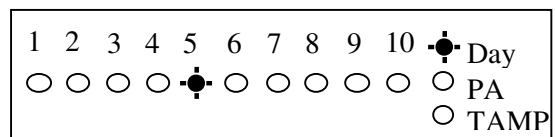

6.6.2 - How to Setup Bell Time

This is the duration that the external bell output is active. The range is 01-20 minutes. The default is 14 minutes.

e.g. Change the **Bell Time** from 14 to 15 minutes.

- Under Engineer mode
- Press **5** to select Setup system.

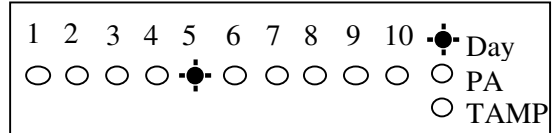

- Press **2** to select bell time item.

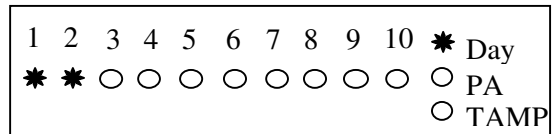

- Press **1** and **5** to change 15 minutes.

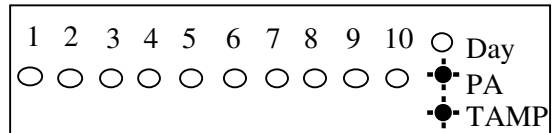

- Press **SET** to accept the change.
- Or press **RESET** to cancel. Press **SET** to Return to Engineer mode.

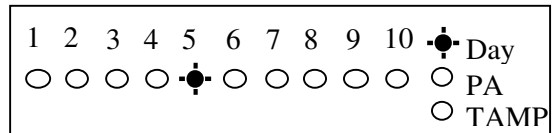

6.6.3 - How to Setup Rearm count

After an alarm the panel will automatically rearm itself when the external siren (Bell) timer has expired. Any Zones and tamper, panic which still remain open at that time will be automatically omitted.

The default is 3 rearms. 0 = no rearms, 1-8= number of rearms, 9= always rearm

Change the **Rearm Count** from 3 to Always rearm.

- Under Engineer mode
- Press **5** to select system item.

- Press **3** to select rearm count item.
LED 1 ON indicate you enter only 1 digit.

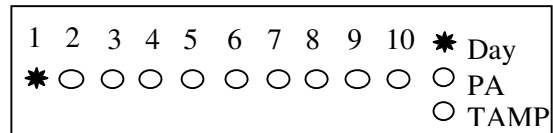

- Press **9** to change to always rearm.

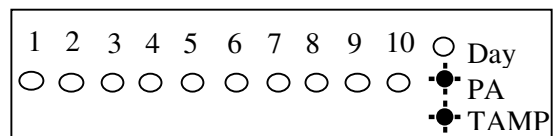

- Press **SET** to accept the change. Or press **RESET** to cancel. Press **SET** to return to engineer mode.

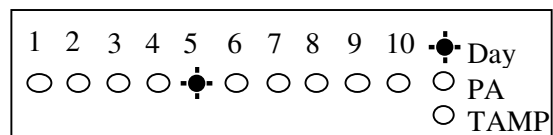

6.6.4 - How to Setup Bell delay time

This delays the activation of the Bell for the required time. The range is 00-10 minutes. The default is 00 minutes.

Change the Bell Delay time from 0 to 1 minute.

- Under Engineer mode
- Press **5** to select system item.

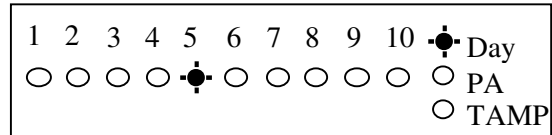

- Press **4** to select bell delay time item.
LED 1 and 2 ON indicates you enter only 2 digits.

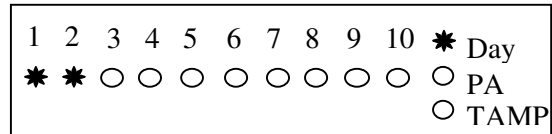

- Press **0 1** to change bell delay time.

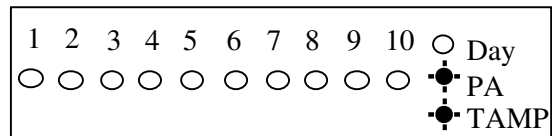

- Press **SET** to accept the change or press **RESET** to cancel. Press **RESET** to return to Engineer mode.

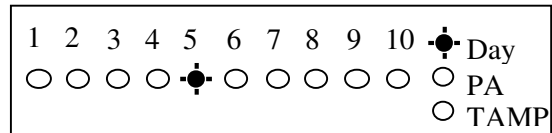

6.6.5 - How to Restore to factory value using menu

You will change the value of all parameters to factory default value when you set it.

CAUTION: All configurations of the panel are reset to reset to factory default conditions.

To default to factory settings:

- Under Engineer mode to top of menu.
LED 1~10 is flashing.
- Press **OMI** twice within 2 second.
All system setting returns to factory default.

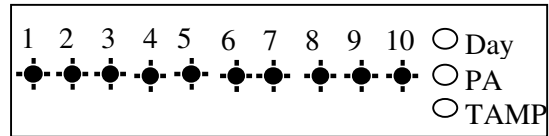

NOTE: if Lock Engineer flag is ON, Engineer Code can not reset to factory default

6.7 - View Event Log

After selecting Alarm Log the zone, PA and Tamper LED's will show the latest event

A flashing LED indicates the zone that was first activated.

Any other LED lit was activated after the first event but before system unset.

- Under Engineer mode.
- Press **🎵** to select view alarm event.
LED 1 flashing indicate Zone 1 is triggered first.
TAMPER is triggered after Zone 1

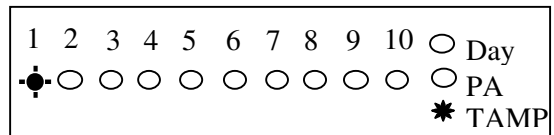

- Press **RESET** to leave view alarm log menu.

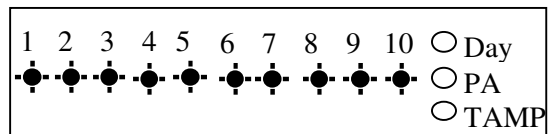

How to clear all alarm events?

- Under Engineer code
- Press **🎵** to select view alarm event.
- Press **9** to clear all alarm events.
All LEDs will go out and the panel will emit a confirm sound to indicate clear all alarm event.

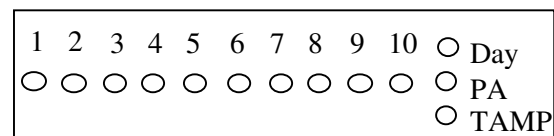
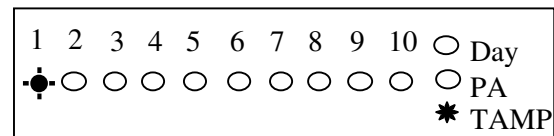

- Press **RESET** to leave view alarm log menu.

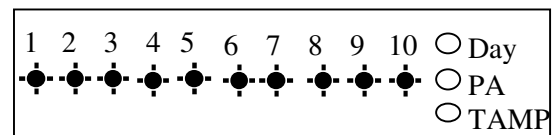

6.8 - Test System

This function has two parts in Test System: **Test output, Walk Test,**

6.8.1 - How to Test Outputs

The test outputs are: **0 = BELL, 1 = Strobe, 2 = Speaker,**

- Under Engineer code
- Press **8** key to Select Test System.

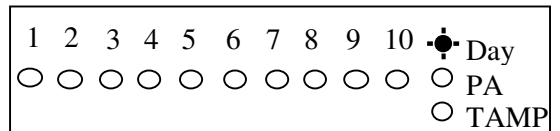

- Press **0** key to select Bell test.

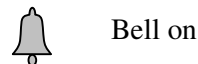
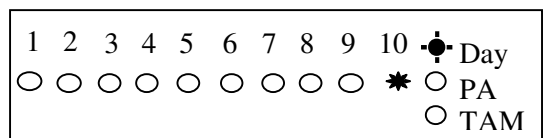

- Press **1** key to select Strobe test.

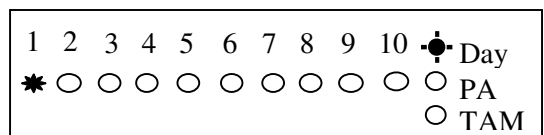

- Press **2** key to select Speaker test.

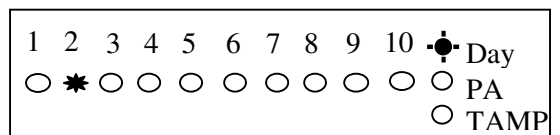

- Press **RESET** key to exit current level. Press **RESET** To return to Engineer mode.

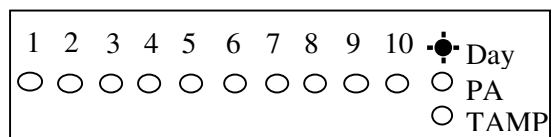

6.8.2 - How to enter Walk Test

The walk test function allows check each Zone trigger, Zone tamper, Detector tamper, Control Panel tamper, Bell Box tamper, Remote Keypad tamper. In order to verify that they are functioning correctly. A tone is generated as each zone or tamper is activated (opened).

e.g. Trigger Zone and Zone tamper

- Under Engineer code
- Press **8** key to Select Test System.

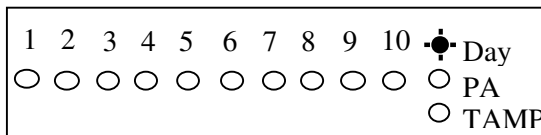

- Press **8** key to select Walk test.
Trigger zone 1, when a zone is successfully tested, the LED is on, Zones are added to list as each one is activated.

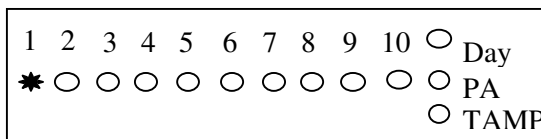

- Trigger detector tamper and its appropriate led will light.

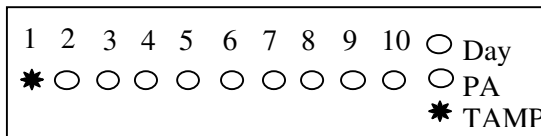

- The Tamper LED comes on when tested.

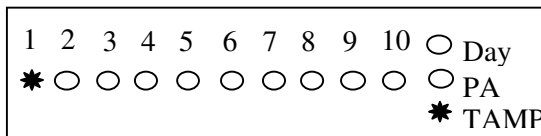

- Press **RESET** key to exit current level.

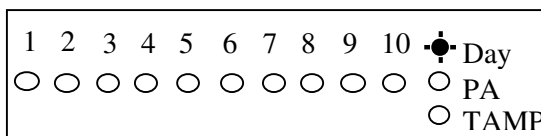

6.8.3 - How to Exit Engineer Program Menu

- Under Engineer menu.
- Press **RESET** key return to top of engineer menu.

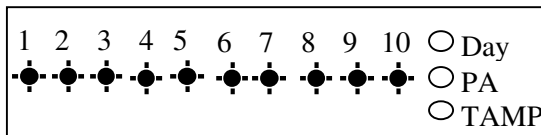

- Press **RESET** key to exit engineer program mode. and check system faults (all Tamper, TA zone, PA zone, Fire zone is open)

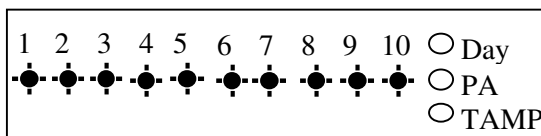

- When no fault, press any key to exit.



- Return to DAY mode.

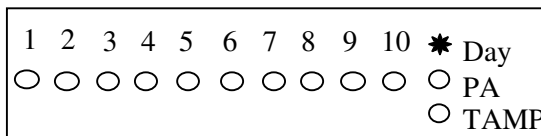

Section 7 - Using System





After you have finished system settings, you can then use the system. This section gives an operation of how to set and unset the system as well as how to reset after an alarm.

7.1 - Setting the System

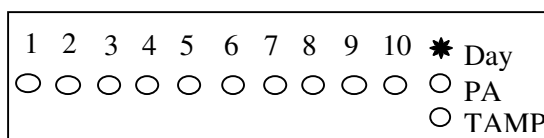



The panel has three programs: Program Full, Program Part1, Part2. Each can be programmed independently in the Engineer operations mode. So you can set the system to the corresponding mode: **Full Mode, Part1 Mode and Part2 mode**. You can set them as follows.

- System is in Day mode and has power.

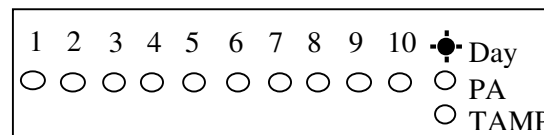

- Enter User code/Manager code    
Day LED will flash 5 second, you can now select arm mode.



- Press  key to select Full arm mode,
Or press  key to select Part 1 arm mode,
Or press  key to select Part 2 arm mode.
Or press  key to exit.

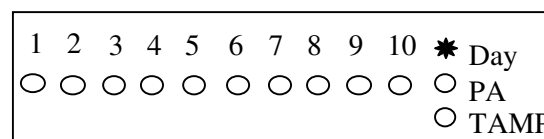

- If it has faults in system, you can see the fault from LED and the fault tone will be generated, you should solve the fault and try exit mode again.
e.g. Detect 1 activated.

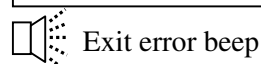
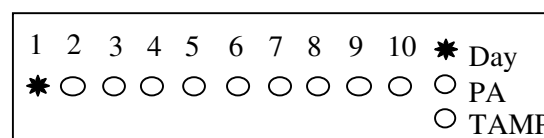

- Press  key quick set the system.(Optional)

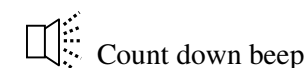

- After you selected arm mode, Day LED became steady. And will go out when armed.

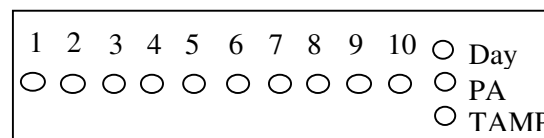

7.2 - How to OMIT a zone(s)

If you cannot set the alarm system because a detector is faulty and in constant alarm you may need to omit its zone from the alarm system. A zone which has been omitted cannot cause an alarm. Omitted zones will be restored after the system is unset.

Before a zone can be omitted it has to be enabled by the engineer as “Setup zone attrs/Omit Allowed” zone.

- As system is setting (for more information see “How to Setting the System”)

- Press **OMIT** key to go into omit zone window, and all allowed omit zone is lit.

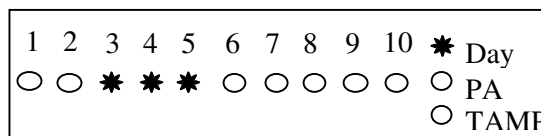

- e.g. To omit zone 4

Press **4** to omit zone 4, corresponding is LED OFF.
Press same key to toggle ON/OFF.

Note: 1-9 key= zone1 –zone 9, 0 key = zone 10.

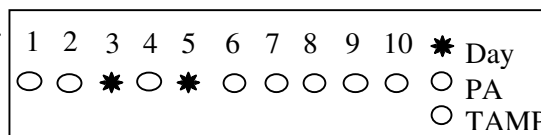

- Press **SET** key to accept and continue setting or press **RESET** key to cancel omit function.

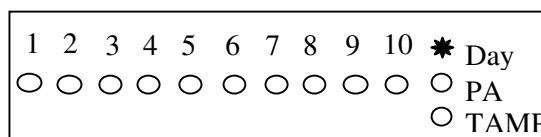

- System work in setting mode

7.3 - Unsetting the System

To unsetting the system in SET as follows.

- System is in Set mode.

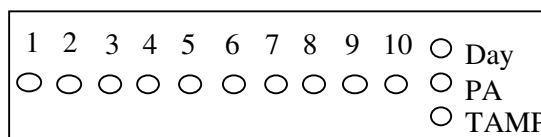

- Enter User code/Manager code **???** System returns to Day mode.

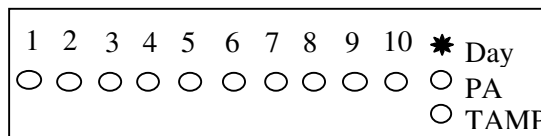

CAUTION: Entering an invalid user code will operate the code tamper. After 9 incorrect keys pushes a full alarm condition will be generated.

7.4 - How to UNSET from Alarm and RESET the system

You can unset the system in SET and reset it after an alarm, Tamper or PA.

The system will be programmed to be reset by the user or engineer. This is dependent on System flags set up. See **Engineer mode / Setup System/ Flags 1.**

e.g. Control Panel tamper trigger alarm

- System is in Set mode.

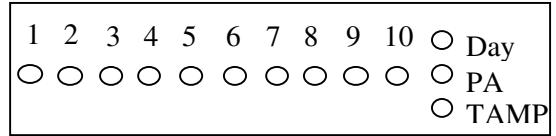

- Enter User code/Manager code

Will stop sounders in alarm and the LED keypad will show alarm event. First event is flashing, others lit.

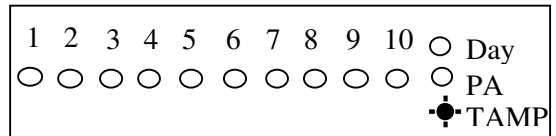

- Press System returns to Day mode.

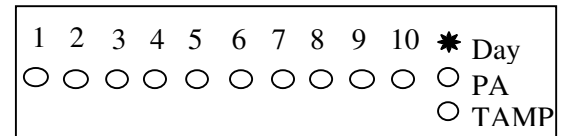

7.5 - How to use Panic Alarm on keypad

Should you need to attract attention, the full alarm signal can be activated at emergency by pressing 0 and 5 together

Press & simultaneously, the system and external sounder will sound immediately.

Section 8 - Maintenance

Once every three months,

- Test all detectors.
- Check loudspeaker of control unit.
- Test sirens and strobes of the bellbox.

Additionally, once every year,

- Check external bell box
- Test detector feature

Additionally, once every three years,

- Replace the rechargeable battery in the Control Unit.
-

Section 9 - Troubleshooting Guide

Control Unit (CU)

Symptoms	Possible cause & cures
Power indicator off. No response from panel.	No power supply to unit. Check connectors to mains and backup battery.
Power indicator does not light up but the RKP can work.	Main supply is out. It is operating from backup battery. Check power connections/adaptor.
TAMPER	Tamper triggered, check tampers (panel, keypad, detectors, bellbox). Or Low backup battery condition; check battery fuse. Replace panel battery as soon as possible.
No response to detectors	Check if Links are across used zones.. Remove them.
No response to keystroke	Power reset (both mains and backup battery)

Remote Keypad (RKP)

Symptoms	Possible cause & cures
Keypad not working	Check the connection to Keypad with Control Panel
Extra Keypads not work at any time	Check address jumper in the back PCB of keypad.

Remark: If you have any problem with the alarm system. To default to factory settings, please follow sections 5 explained in this manual.

Control Panel

When system flag, EN Compliant flag is ON, There are 2 possible faults:

In Day mode the flashing Tamper LED indicates a fault. Entry of a valid code will show up to 2 LEDs flashing, prompting the user to accept the fault by pressing the  key.

Mains Fail

- System is in Day mode.
Day LED ON, TAMP LED flashing.

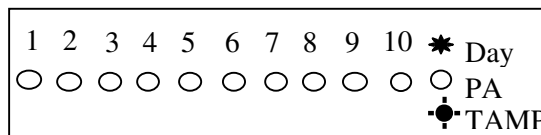

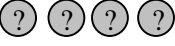
- Enter User code / Manager code 
Show Z1 LED flashing.

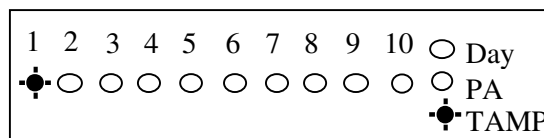

- Press  key to accept the fault.

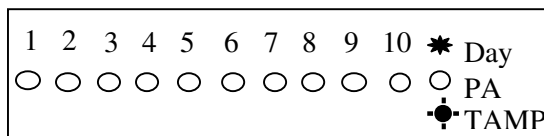

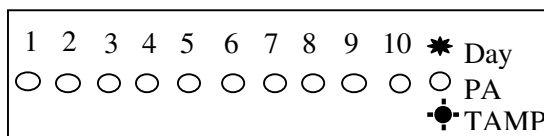

Low Battery Volts

- System is in Day mode.
Day LED ON, TAMP LED flashing.

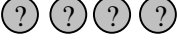

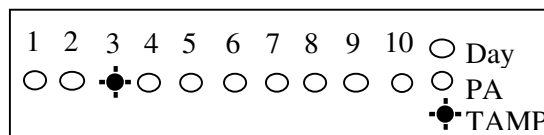
- Enter User code/Manager code 
Show Z3 LED flashing.



- Press  key to accept the fault.

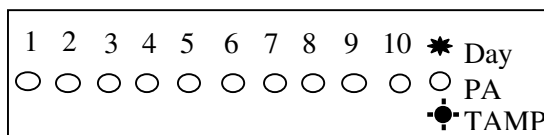

Key Board Lockout

When you enter 4 groups of invalid codes, keyboard will lockout for 90 seconds.

And then you enter the second 4 groups invalid code, the keyboard will go on lockout for 90 seconds.

When you go on enter 1 invalid code again, system will cause an alarm condition.

Section 10 - Specifications

10 ZONE ONBOARD LED ALARM PANEL	
Type of Alarm Panel	Microprocessor based control unit
Housing	ABS
Entry Delay	default 45 seconds, programmable
Exit Delay	default 45 seconds, programmable
Alarm Zone	10 Zones - Programmable function
Remote Keypad	Up to 4 LED Keypads
Tamper	-Ve loop
External Bell box output	DC12V, max current : 400mA, adjustable timer(1-20 mins)
Strobe output	DC12V latching
External Speaker	DC12V 16ohm, max current : 220mA
Set+ output	0V in Day mode 13V in Set mode
Siren Duration	Default 14 minutes
Current consumption control panel	Standby : 50mA Alarm : 100mA
Current consumption for LED keypad	Standby : 40mA Alarm : 70mA
Low voltage output	13.8V DC stabilized(+/- 5%) up to 350mA
Rechargeable battery	DC12V, up to 2.1Ah
Charge Voltage	13.8V dc
Board fuse on control panel	1.6A 20mm quick blow
Main input fuse	1.6A 20mm quick blow
Total Current output	1A when supported by a fully charged battery
Mains supply voltage	230V AC (+/- 10%) 50Hz max load 0.5A
Ambient operating temperature	0°C ~ 40°C
Dimensions (mm)	253 x 195 x 61

Appendix 1 – Zone - Location Table

Zone Number	Location
1	
2	
3	
4	
5	
6	
7	
8	
9	
10	

Disposal and Recycling

Batteries and waste electrical products should not be disposed of with household waste. Please recycle where these facilities exist.

Technical Support

For technical help with this product, please email info@leeds.com.hk.