

# CONTENTS

Section	Page No.
<b>1.00 Control Panel Installation</b>	<b>2</b>
1.01 Introduction to Control Panel	2
1.02 Pre-installation Testing	2
1.03 Mounting Control Panel	2
1.04 Wiring and Safety Information	3
1.05 ST5000 Printed Circuit Board Wiring Terminals	4
1.06 ST5000 Control Panel Wiring Terminal Description	5
1.08 ST5000 Fuse Specifications	5
1.09 Wiring External Bell Boxes	6
1.10 Wiring Passive Infrared Detectors	7
1.11 Wiring System Tamper	8
1.12 Wiring Magnetic Contacts	8
1.13 Wiring K6550 Remote Keypad	9
1.14 Wiring SL6600 Sleep Watch Remote Keypad	9
1.15 Commissioning the System	10
1.16 Trouble Shooting	11
<b>2.00 Engineer Installation Programming Section</b>	<b>13</b>
2.00 Control Panel Factory Default Settings	13
2.01 Day Mode	14
2.02 Engineer/Installation Programming	14
2.03 Exit Time Adjustment	14
2.04 Entry Time Adjustment	14
2.05 Siren Duration Time Adjustment	14
2.06 Part Guard Exit Time Adjustment	15
2.07 Disable/Isolate Zones in Part Guard	15
2.08 Sleep Watch Delay Time Adjustment	15
2.09 Enable Sleep Watch Automatic Rearm	15
2.10 Sleep Watch Automatic Rearm Time Adjustment	16
2.11 Enable Sleep Watch Arm and Disarm Part Guard	16
2.12 Display Engineer Message on K6600 Remote Keypad	16
2.13 Display Zone Location Names on K6600 Remote Keypad	17
2.14 Miscellaneous Section 1	18
2.15 Enable Quick Set	18
2.16 Enable Special Switched Positive	18
2.17 Enable Exit Strobe Flashes	19
2.18 Enable Engineer Reset	19
2.19 Enable Engineer Burn In Code	19
2.20 Enable Push Button Final Set	19
2.21 Enable Day LED Illuminated Day Mode	19
2.22 Enable Entry Timed Out Full Alarm	19
2.23 Enable Switched Positive 0 Volts	20
2.24 Zone Type Description	20
2.25 Changing Full Guard Zone Type	21
2.26 Changing Part Guard Zone Type	22
2.27 Change Engineer Programming Code	22
2.28 Set System Date	23
2.29 Set System Time	23
2.30 Exit Engineer Installation Programming	23
2.31 Reset Control Panel to Factory Default Settings	23
2.32 Reset Control Panel without Losing Engineer Log	23
<b>3.00 Engineer Reference Guide</b>	<b>24</b>
3.01 Engineer Programming Record	26
<b>4.00 Control Panel Technical Specifications</b>	<b>28</b>

### 1.00 Control Panel Installation

#### 1.01 Introduction to the Control Panel

The control panel has been designed for both installer and user friendliness. The factory default settings have been carefully selected to suit most installation needs. However most functions are fully programmable for flexibility when installing the system. All changes made are stored within a Non Volatile Memory (NVM) and are retained even when there is complete loss of power.

**Please read these instructions carefully before attempting to install this control panel. Ensure the user instructions are given to the user after installation.**

#### 1.02 Pre-testing the Control Panel before Installing

1. Release keypad cover and unscrew the two screws from the front cover.
2. Remove the cover and put in a safe place with the screws. If connecting K6600, K6550 or SL6600 Sleepwatch remote keypad follow instructions as described within the keypad.
3. Restrain front cover Tamper Spring under Keypad PCB
4. Connect a fully charged 12V 1.2 Ah sealed lead acid battery, black lead wire to the negative (-) of the battery terminal and the red lead wire to the positive (+) of the battery terminal.
5. The control panel Day LED illuminates, Power LED flashes and LCD display shows Fault Mains
6. Press: **PROG**
7. Enter: **1 2 3 4**
8. Press: **0 5** Walk test (PA & Tamper give the same tone)
9. Remove and replace each zone link, the corresponding zone LED will illuminate and also beep indicating which zone is activated, after testing all the zones and tamper.
- 10 Press: **RESET** twice, disconnect and remove the battery.

These simple tests will demonstrate that the control panel (and remote keypad if fitted) are working correctly. Disconnect the battery from the control panel in preparation for wiring, and release front cover Tamper spring

**Note: If alarm sounds when connecting the battery enter 1 2 3 4 and press reset button**

**Note: If LCD display indicates low battery, change the battery before proceeding with testing the control panel.**

#### 1.03 Mounting the Control Panel

The main control panel unit should be positioned out of reach of children in a secure place close to a mains electricity supply. The unit should not be fitted to a flammable or uneven surface.

1. Remove the PCB by disconnecting the AC supply cable from the transformer and also from the speaker connector, put the PCB in a safe place.
2. Using the rear panel as a template, mark the positions of the mounting holes. The mounting surface must be solid. Do not fit to a flammable or uneven surface. Drill mounting holes and fit wall plugs.
3. Thread the mains supply AC power cable through the smaller aperture in the rear casing.

**At this stage, do not connect the AC supply cable to the panel.**

4. Attach rear panel to wall using at least three 30mm No.8 wood screws.
5. Replace the PCB and reconnect the AC and speaker connectors.

## Contents

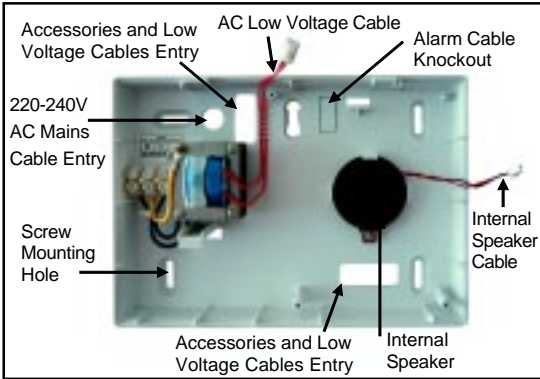

**ST5000 BACK PLATE**

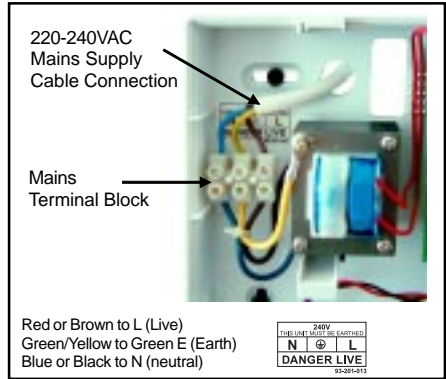

**ST5000 Transformer Wiring**

## 1.04 Wiring and Safety Instructions

### WARNING: ELECTRICITY CAN KILL

Ensure electricity is switched off at the mains before installing and fitting the mains supply

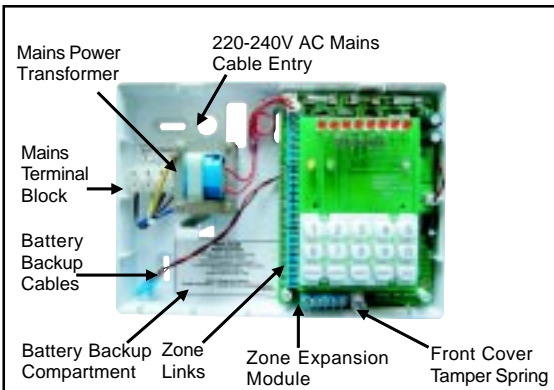

**ST5000**

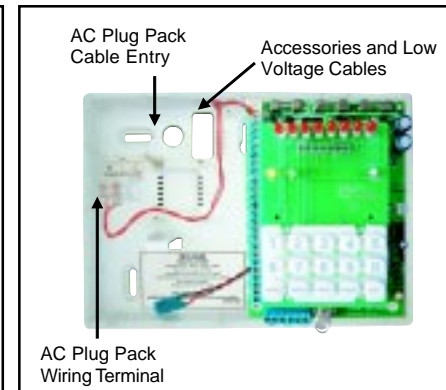

**ST5000 Low Voltage  
16.5V AC Plug Pack Wiring**

1. The control panel must be wired according to Current National Wiring Regulations if fitted with an internal transformer.
2. A readily accessible device for disconnecting from the mains (e.g. 3 amp un-switched fused spur) must be provided as part of the installation.
3. If the control panel is wired to a 13 amp wall socket, a 3 amp 250V fuse must be used
4. Use mains 2 core cable and earth cable capable of carrying the rated current (i.e. at least 1mm<sup>2</sup>). The control panel must be wired to earth.
5. Wiring of the mains supply to the transformer terminal block in the control panel should pass through the smaller aperture in the rear casing of the panel, NEVER connect the mains supply directly to the PCB.
6. The unit requires wiring to a suitable earth, refer to National Wiring Regulations.
7. It is recommended that the unit is wired by a qualified electrician. Check for hidden cables and/or pipes before drilling.
8. Use safety goggles when drilling or hammering in cable clips.

1.05 ST5000 Printed Circuit Board (PCB)

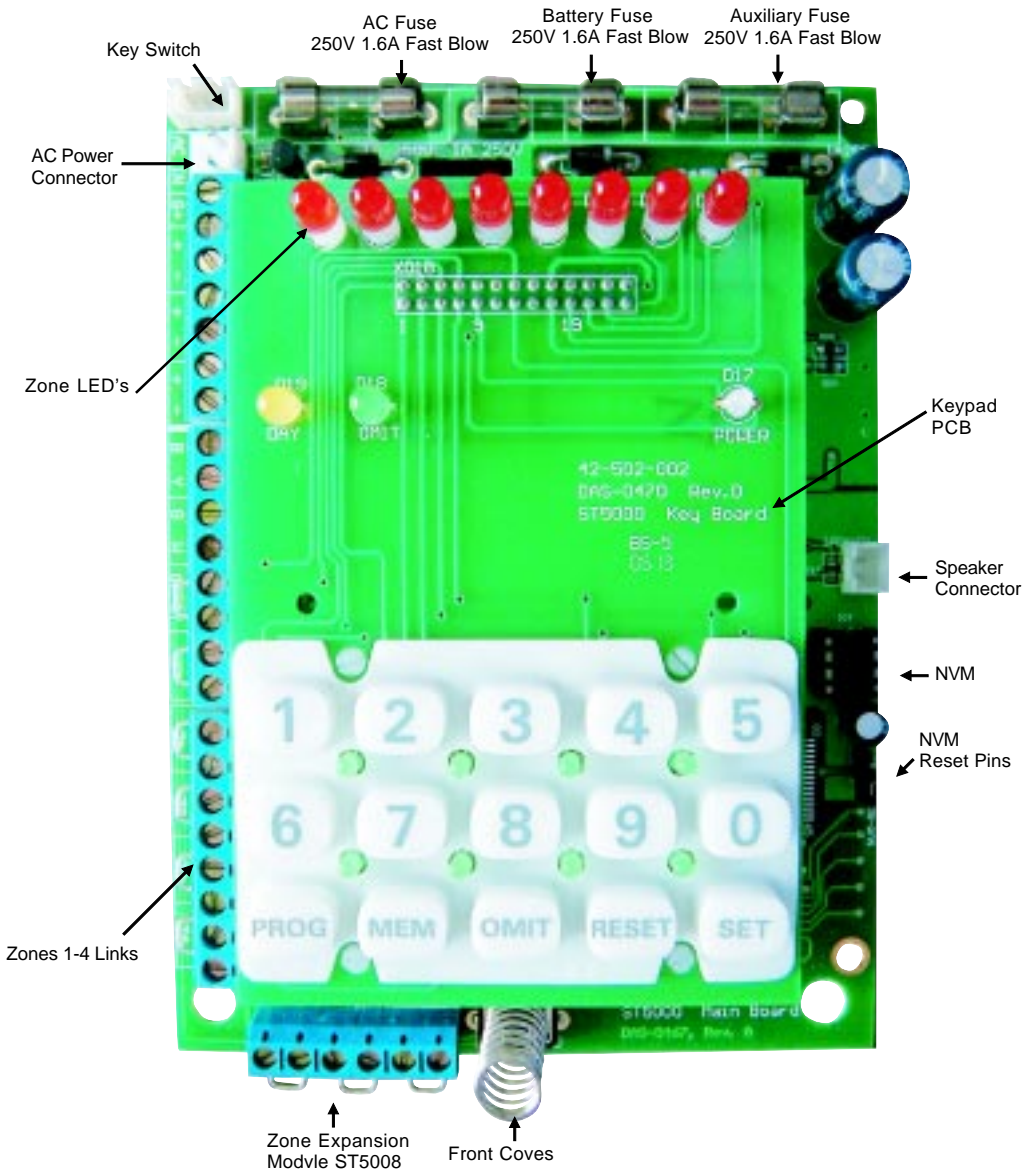

<b>1.06 PCB Terminals ST5000</b>		
<b>Terminal</b>	<b>Description</b>	<b>Remarks</b>
AUX 1 -	Regulated Auxiliary Supply Negative	
AUX 1 +	Regulated Auxiliary Supply Positive	Maximum Output 250mA
SW +	Switched Positive Supply	Maximum Output 250mA
STB +	Latching Strobe Positive Supply	
STB -	Latching Strobe Negative Supply	
BELL +	Bell Positive Supply	
BELL -	Bell Negative Supply	
NETWORK B	Remote Keypad & Sleep Watch Data In	
NETWORK Y	Remote Keypad & Sleep Watch Data Out	
SAB 1 G/W	Self Contained Bell Output (SCB)	Leave Link In If Not Used
SAB 1 RT	Self Contained Bell Output (SCB)	
TAMP	Tamper Alarm Zone Loop	Leave Link In If Not Used
Z1-Z4	Normally Closed Positive Fully Programmable Zone Loops	Leave Link In If Zone Not Used
<b>1.07 Fuses ST5000</b>		
<b>Fuse</b>	<b>Description</b>	<b>Rating</b>
AC	Power Supply Output Fuse	Fast Blow F1.6A, 250V, 20 X 5mm
AUX	Auxiliary Fuse	Fast Blow F1.6A, 250V, 20 X 5mm
BATT	Battery Fuse	Fast Blow F1.6A, 250V, 20 X 5mm

1.09 Bell Box Wiring

**ST5000**

**STANDARD**

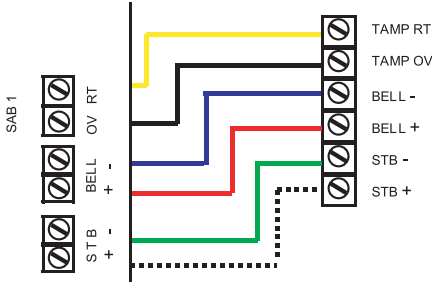

**ST5000**

**VORTEX**

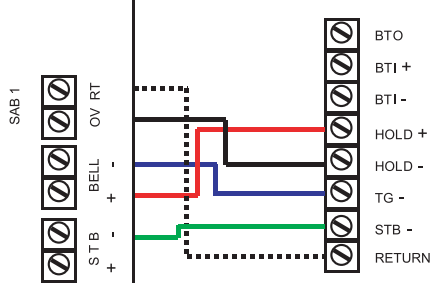

**ST5000**

**FLASHGUARD**

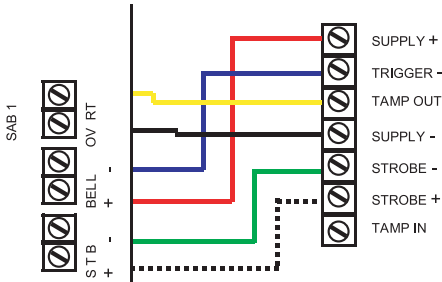

**ST5000**

**CITADEL DEFENDER**

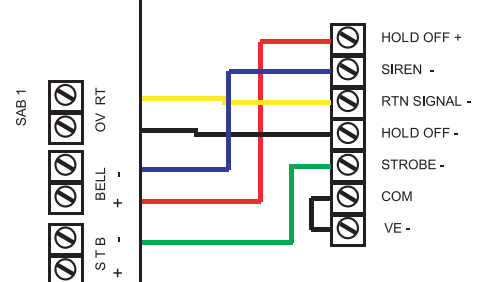

**ST5000**

**NOVAGUARD IE**

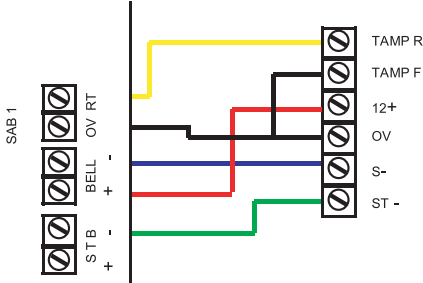

**ST5000**

**TATE**

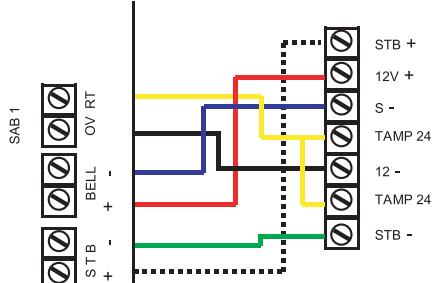

**ST5000**

**LYNTECK UNIVERSAL**

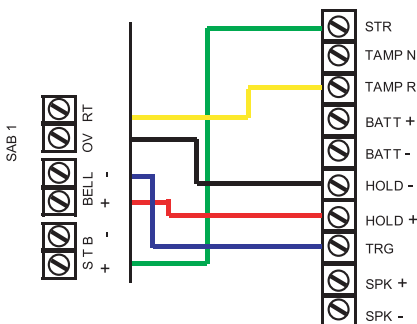

**ST5000**

**VENTCROFT CLASSIC/SPRINT**

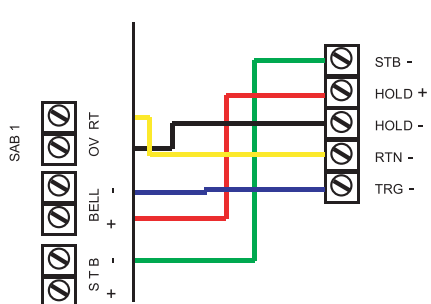

## 1.10 Wiring Passive Infrared Detectors

### Single Passive Infrared Detector

Consult Passive Infrared Detectors manufacturers installation instructions before wiring to control panel.

If two or more Passive Infrared Detectors are wired to a zone, wire power in parallel, wire alarm and tamper in series.

Use 6 core multi stranded cable .

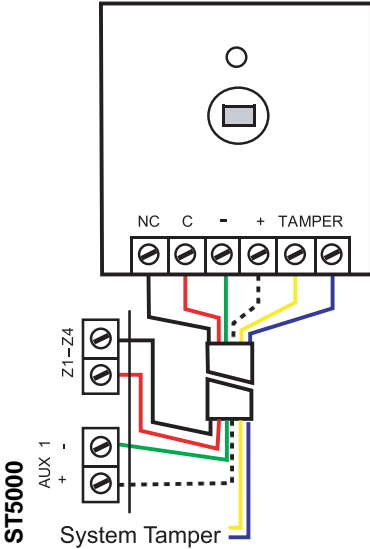

Terminal	Connection	Wire Colour
AUX 1 +	Detector Positive (12+)	White
AUX 1 -	Detector Negative (0V)	Green
Z1-Z4	NC	Black
Z1-Z4	C	Red
System Tamper	Tamper	Yellow
System Tamper	Tamper	Blue

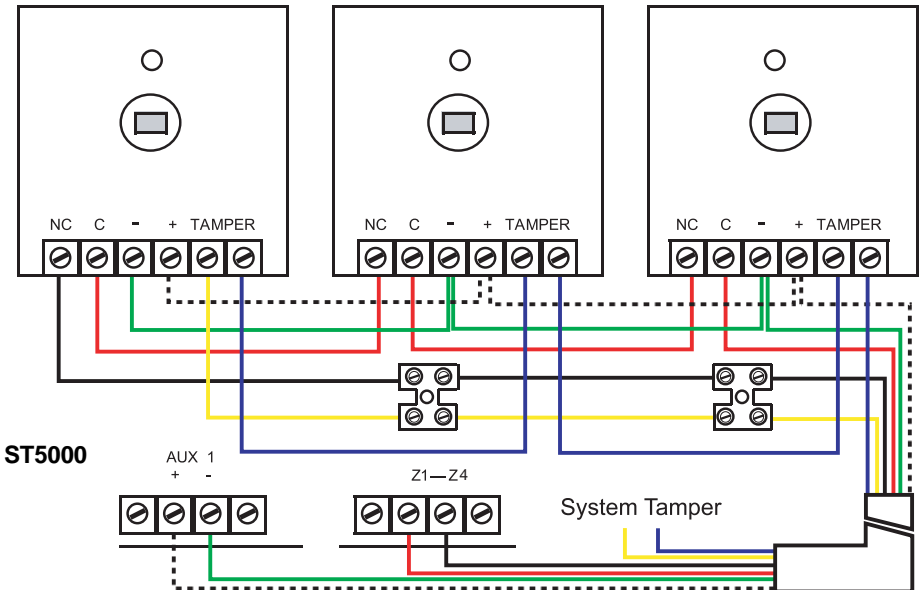

## 1.11 Wiring System Tamper

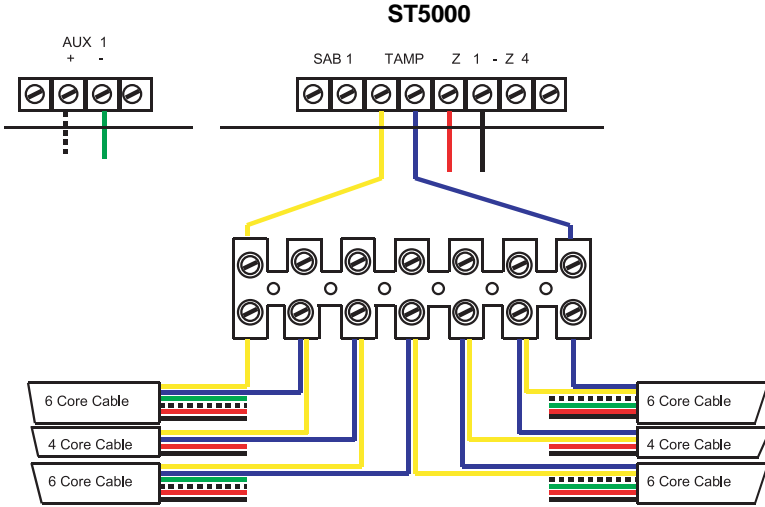

## 1.12 Wiring Magnetic Contacts

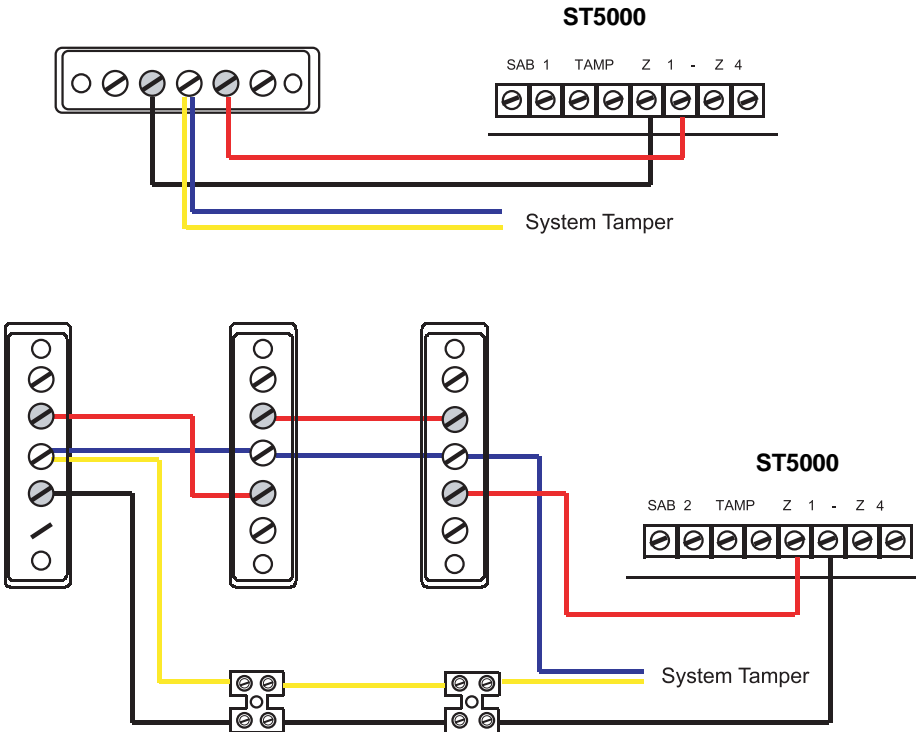

### 1.13 Wiring K6550 & K6600 Remote Keypad

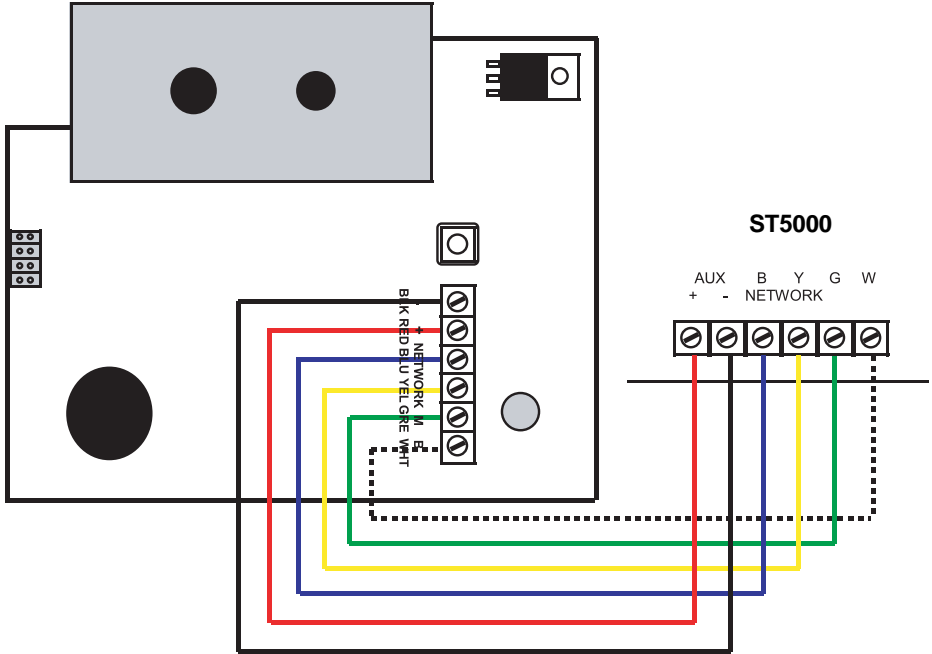

### 1.14 Wiring SL6600 Sleep Watch Remote Keypad

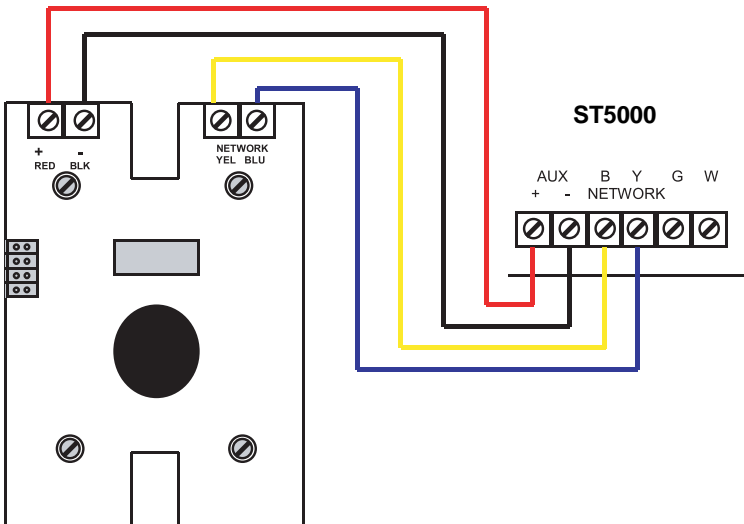

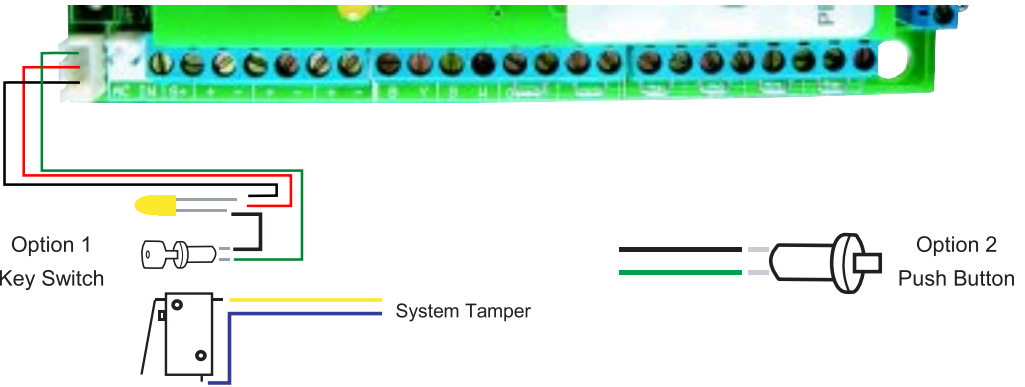

Option 1 Key Switch Wiring		
Terminal	Connection	Wire Colour
G	To Common -ve	Black
L	To LED +ve	Red
K	To Key Switch	Green

Option 2 Push Button Wiring		
Terminal	Connection	Wire Colour
G	To Push Button	Black
L	Not Used	Red
K	To Push Button	Green

**Note:** Use only a non latching momentary key switch with an LED or push button with this panel. The yellow LED operates exactly as the day LED on the control panel and therefore tells you if the panel is armed or disarmed. You can only wire either a key switch option number 1 or push button final set option number 2, which is the factory default setting. If using option number 1, you must disable option 2 push button final set, in engineer programming under section number 2.20.

## 1.15 Commissioning the System

Fit a fully charged 1.2Ah 12Vdc sealed lead acid rechargeable battery to the connectors inside the control panel. After fitting the battery Day LED illuminates and Power LED flashes, LCD displays Fault Mains.

Replace the front cover of the main unit, if alarm sounds enter your master user code 1 2 3 4 to silence alarm and press the reset button.

Go to USER manual page No.14 testing system and follow the instructions.

### IMPORTANT

There are no user serviceable parts contained within the control panel and keypads.

DO NOT attempt to interfere with, or alter any of the electronic components. To do so may damage the electronic circuitry and will invalidate your warranty.

The Melcom alarm system can provide valuable protection for your home and property if used properly. However, the system can not guarantee complete protection against burglary or robbery. Therefore, the manufacturer, distributor or supplier will not be held responsible for any loss or damage that may occur.

## Contents

---

Every effort has been made to provide accurate information, however slight variations can occur. We also reserve the right to make changes for product improvement at anytime.

We recommend that you check your local by-laws relating to Intruder Alarm Systems. In certain countries you are required by law to:

1. Notify the local police, in writing, within 24 hours of the alarm being installed, the names and address of at least two key holders of the property protected.
2. Instruct the key holders in the operation and silencing of the alarm.
3. Within 48 hours of installation, inform the local Environmental Health Authority of the installation, and which local police station you have notified.
4. Inform the local police of any changes of the key holders, within 24 hours of the change.

### 1.16 Trouble Shooting

**Always disconnect unit mains supply BEFORE removing the front cover**

#### **No Mains Power to the Control Panel**

- Check the AC fuse on the PCB, if blown replace with 1.6Amp 250V fast blow fuse.
- Check for loose wiring into the mains terminal block.
- Check for loose wiring from mains supply.
- Check AC connector is connected correctly to the control panel PCB.

#### **No Battery Power to the Control Panel**

- Check the Battery fuse on the PCB, if blown replace with 1.6Amp 250V fast blow fuse.
- Check Battery wires are connected correctly to the battery; Red +, Black -.

**Note:** *If No Mains Power Supply and Low Battery this is Indicated on the LCD display.*

#### **Unit Does Not Accept Code Upon Power Up**

- If remote SL6600, K6550 LED or K6600 LCD keypads are connected ensure each keypad has a different address.
- Check wiring of remote keypads.
- Disconnect power momentarily so that the system can configure all keypads connected to system.
- Reset NVM to factory default settings.

#### **Unit Will Not Set and Tamper Fault displayed on LCD.**

- Check system tamper, replace link into tamper zone and replace lid to see if this clears the fault.
- Check system tamper wiring.
- Check tamper wiring to detector and sensors.

#### **Unit Will Not Set Fault Zone displayed on LCD**

- Ensure the zone is closed (No movement in that area, windows and doors are closed).
- Check wiring to that zone, replace link and see if system sets.
- Check wiring to detector and sensors.
- If you have a meter, check the resistance to that zone.

### **Day LED Flashing Fault displayed on LCD**

- Enter USER code to set system note which zone is in fault
- Ensure the zone is closed (No movement in that area, windows and doors are closed).
- Check wiring to that zone, replace link and see if system sets.
- Check wiring to detector and sensors.
- If you have a meter check the resistance to that zone.

### **Tamper Fault**

- Replace Tamper Link, press tamer spring if Tamper Fault clears,check wiring.
- Replace SAB Link, press tamer spring if Tamper Fault clears,check Bellbox wiring.

### **Unit Makes No Sound**

- Ensure that the internal speaker is connected to PCB.

### **Remote Keypad Does Not Indicate Power**

- Ensure you are using 6 core wire and that they are wired correctly to keypad and main unit.
- Check Power Fuse on Main Unit PCB, if blown replace with 1.6Amp 250V fast blow fuse.

### **External Bell Box Does Not Work**

- Check wiring connections bell boxes on page 6.

### **Panic Button Does Not Work**

- Ensure zone type is programmed as PA.
- Check wiring to control panel and panic button.
- Check panic button has been reset using the reset key.

### **Sleep Watch Keypad Does Not Work**

- Ensure zones are programmed as Sleep Watch zones.
- Ensure each Sleep Watch Keypad has a different address to Remote Keypads or other Sleep Watch Keypads.
- Check wiring to control panel and Sleep Watch Keypad.
- Check Power Fuse on Main Unit PCB, if blown replace with 1.6Amp 250V fast blow fuse.

<b>2.00 Engineer Installation Programming Section</b>		
<b>2.00 Control Panel Factory Default Settings</b>		
Entry time	30 Seconds	
Exit Time	30 Seconds	
Alarm Time	15 Minutes	
Part Guard Set Time	5 Seconds	
Sleep Watch Zone Delay Activation Time	15 Seconds	
Sleep Watch Zone Automatic Rearm Time	15 Minutes	
	<b>Full Guard</b>	<b>Part Guard</b>
Zone 1	Timed Entry/Exit	Timed Entry/Exit
Zone 2	Walk Through	Walk Through
Zone 3	Instant	Timed Entry/Exit
Zone 4	Instant	Instant
Zone/Tamper	Tamper	Tamper
Chime Zones	Clear	
Date & Time	Clear	
Day LED On	Enabled	
Disabled/Isolated Zones	Clear	
Double Knock Zones	Clear	
Engineer Code	9 9 9 9	
Engineer Code Burn In	Disabled	
Engineer Service Timer	Disabled	
Engineer Reset	Disabled	
Entry Time Timed Out Alarm	Disabled	
Final Set	Disabled	
Fire Zones	Clear	
Master User Code	1 2 3 4	
Push Button Final Set	Enabled	
Quick Set	Disabled	
Secure Zones	Clear	
Sleep Watch Zones	Clear	
Sleep Watch Keypad Disarm Part Guard	Disabled	
Strobe Exit Flashes	Disabled	
Switched Positive	Normal	
User Codes 2,3,4,5,6	Disabled	

## 2.01 Day Mode

This is the normal (default) setting of the control panel. The alarm will only activate if the PA, Fire Zones or Keypad PA are activated.

## 2.02 Engineer Installation Programming

To enter the engineer programming mode:

Press: **PROG** All red LED's illuminated.

Enter: **1 2 3 4** Zone LEDs extinguished.  
TAMPER and DAY LEDs stay illuminated.

Press: **PROG** All red LEDs illuminated.

Enter: **9 9 9 9** Zone LEDs extinguished.  
PA and DAY LEDs stay illuminated.

You are now in Engineer Programming.

Parameters can be adjusted as described in sections 2.03 to 2.30.

K6600  
LCD Display

User  
Programming

Engineer  
Programming

**Note: For user programming functions refer to engineer quick reference guide or user manual.**

## 2.03 Exit Time Adjustment

This is pre-set at 30 seconds. Exit time is the maximum period of time between setting the alarm, and leaving the property via the EXIT route.

Press: **1** Zone 1,2,3 LEDs illuminate.

Input a new Exit time (max. 255 seconds). Eg. for 70 seconds input 070, for 95 seconds input 095, etc. When the third digit is input the panel will give an acceptance tone and will revert back to ENGINEER PROGRAMMING MODE.

Exit Time  
030

Engineer  
Programming

## 2.04 Entry Time Adjustment

This is pre-set at 30 seconds. Entry time is the maximum period of time between activation (opening of front door) of ENTRY/EXIT route and the alarm sounding. It will allow time to enter the property and switch off the system.

Press: **2** Zone 1,2,3 LEDs illuminate.

Input a new Entry time (max. 255 seconds). Eg. for 45 seconds input 045, for 15 seconds input 015, etc. When the third digit is input the panel will give an acceptance tone and will revert back to ENGINEER PROGRAMMING MODE.

Exit Time  
030

Engineer  
Programming

**Note: To comply with EN50301-1 entry time should not exceed 45 seconds, also internal siren activates if user code not entered before timing out, full alarm 30 seconds later.**

## 2.05 Siren Duration Time Adjustment

The Siren Duration time is pre-set to sound for 15 minutes, when activated. Do not set the alarm for a longer period than that specified by legislation. You can adjust the siren to sound for less than 15 minutes.

Press: **3** Zone 1,2,3 LEDs illuminate.

## Contents

Input a new Siren time (max. 255 minutes). Eg. for 10 minutes input 010, for 5 minutes input 005, etc. When the third digit is input, the panel will give an acceptance tone and revert back to ENGINEER PROGRAMMING MODE.

Siren Time  
015

**Note: To comply with EN50301-1, siren time must be adjusted between 2 minutes (002) and a maximum duration of 15 minutes (015).**

Engineer  
Programming

### 2.06 Part Guard Exit Time Adjustment

Part Guard set time is the maximum period of time between setting the alarm, and leaving the protected area, this is pre-set at 5 seconds.

Press: (4) (1) Zone 1,2,3 LEDs illuminate.

Part Guard Time  
005

Input a new time (max. 255 seconds). Eg. for 10 seconds input 010, for 25 seconds input 025, etc. When the third digit is input the panel will give an acceptance tone and revert back to ENGINEER PROGRAMMING MODE.

Engineer  
Programming

### 2.07 Set Zones Disabled/Isolated in Part Guard

In this location enter zones to be Disabled/Isolated in part guard arming.

Press: (4) (2) Enter zone numbers to be omitted the corresponding LEDs will flash.

To reset that zone, toggle the corresponding zone

Zones Disabled  
None

Press: (RESET)

Engineer  
Programming

### 2.08 Set Sleep Watch Zone Delay Activation Time

In this location activation of a sleep watch zone will not activate a full alarm until after the zone delay time has timed out, this is pre-set at 15 seconds.

Press: (4) (3) Zone 1,2,3 LEDs illuminate.

S/W Delay Time  
015

Input a new time (max. 255 seconds). Eg. for 10 seconds input 010, for 25 seconds input 025, etc. When the third digit is input the panel will give an acceptance tone and revert back to ENGINEER PROGRAMMING MODE..

Engineer  
Programming

**Note: If a sleep watch zone is activated a valid user code must be entered to stop activation sequence**

### 2.09 Enable Sleep Watch Zones Automatic Rearm

In this location, after the user has pressed the sleep watch button to disarm sleep watch zones, they will automatically rearm after the period of time programmed in location section 2.10 has timed out.

Press: (4) (4) Zone 1 LED Flashing = Sleep Watch Automatic rearm enabled.  
Toggle Key 4 to disable function.

S/W Rearm  
Disabled

Press: (RESET) and revert back to ENGINEER PROGRAMMING MODE.

Engineer  
Programming

## 2.10 Sleep Watch Zone Automatic Rearm Time

In this location, set sleep watch zones automatic rearm time, this is pre-set at 15 minutes.

Press: (4) (5) Zones 1,2,3 LEDs illuminate

S/W Rearm Time  
015

Input a new time (max. 255 minutes). Eg. for 10 minutes input 010, for 25 minutes input 025, etc. When the third digit is input the panel will give an acceptance tone and revert back to ENGINEER PROGRAMMING MODE.

Engineer  
Programming

## 2.11 Enable Sleep Watch Arm and Disarm Part Guard

The Sleep Watch keypad can be programmed to arm and disarm part guard by pressing the Sleep button for 3 seconds.

Press: (4) (6) Zone 1 LED Flashing = Sleep Watch Datch Keypad disarm

S/W Disarm  
Enabled

part guard enabled. Toggle Key 6 to disable function.

Press: (RESET) and revert back to ENGINEER PROGRAMMING MODE.

Engineer  
Programming

## 2.12 Set Installer Message

Enter the following options to display installer message on the K6600 remote LCD keypad when in normal operation mode.

Press: (4) (7)

Message

16 characters can be programmed as the installer message. Enter the 2 digits to represent the character required to be displayed on the LCD keypad. To move the cursor use the MEM key to move left and the OMIT key to move right.

Engineer  
Programming

Press: (RESET) When message is complete.

00. Space	14. 6	28. K	42. Y	56. m
01. (	15. 7	29. L	43. Z	57. n
02. )	16. 8	30. M	44. a	58. o
03. *	17. 9	31. N	45. b	59. p
04. ,	18. A	32. O	46. c	60. q
05. -	19. 8	33. P	47. d	61. r
06. .	20. C	34. Q	48. e	62. s
07. /	21. D	35. R	49. f	63. t
08. 0	22. E	36. S	50. g	64. u
09. 1	23. F	37. T	51. h	65. v
10. 2	24. G	38. U	52. i	66. w
11. 3	25. H	39. V	53. j	67. x
12. 4	26. I	40. W	54. k	68. y
13. 5	27. J	41. X	55. l	69. z

## 2.13 Remote K6600 LCD Keypad Zone Location Display Names

Each zone can be given a location name from the list below. The location name will be displayed upon the K6600 remote LCD keypad display if that zone is activated or has a fault upon arming the system.

Press: (4) (8) Enter zone number

Enter corresponding zone name number from list below

Example: Zone 1 as Front Door enter 35

Press: (1)

Press: (3) (5)

Press: (RESET)

Press: (RESET) and revert back to ENGINEER PROGRAMMING MODE.

Zone Name

Zone 1

Zone 1  
Front Door

Zone Name

Engineer  
Programming

01. Alarm  
02. Apartment  
03. Auxiliary  
04. Babies Room  
05. Back Door  
06. Back Yard  
07. Barn  
08. Basement  
09. Bathroom  
10. Bedroom 1  
11. Bedroom 2  
12. Bedroom 3  
13. Bedroom 4  
14. Boys Room  
15. Building  
16. Ceiling  
17. Coatroom  
18. Computer Room  
19. Daughters Room  
20. Desk  
21. Dining Room  
22. Dock  
23. Downstairs  
24. Driveway  
25. East Room  
26. Studio  
27. Emergency  
28. Entry & Exit  
29. File  
30. Fire

31. Floor  
32. Foyer  
33. Freezer  
34. Fridge  
35. Front Door  
36. Gallery  
37. Garage 1  
38. Garage 2  
39. Gas  
40. Gate 1  
41. Gate 2  
42. Gymnasium  
43. Guestroom  
44. Hallway  
45. Hold Up  
46. House  
47. Internal Door  
48. Interior  
49. Kitchen  
50. Laundry  
51. Library  
52. Loading Area  
53. Lock  
54. Lounge Area  
55. Maids Room  
56. Master Bedroom  
57. Medical  
58. Mothers Room  
59. Nursery  
60. Office

61. Outside  
62. Panic  
63. Patio  
64. Perimeter  
65. Police  
66. Pool  
67. Reception  
68. Roof  
69. Safe  
70. Shed  
71. Shop  
72. Skylight  
73. Sliding Door  
74. Smoke Detector  
75. Store Room  
76. Sons Room  
77. Studio  
78. Study  
79. Sun Room  
80. Tamper  
81. Utility  
82. Vault  
83. Ware House  
84. Wash Room  
85. West Room  
86. Window  
87. Work Shop  
88. Yard

## 2.14 Miscellaneous Section 1

In this section under programming key 5 you can enable or disable any of the following features:

Section	Key No.	Description	Zone LED	Factory Setting
2.15	1	Quick Set	1	Disabled
2.16	2	Special Switch Positive	2	Disabled
2.17	3	Exit Strobe Flashes	3	Disabled
2.18	4	Engineer Reset Any Alarm	4	Disabled
2.19	5	Engineer Code Burn In	5	Disabled
2.20	6	Final Set Push Button	6	Enabled
2.21	7	Day Mode LED illuminated	PA	Disabled
2.22	8	Entry Time Timed Out Alarm	Tamp	Disabled
2.23	9	Switch Positive 0 Volts	Day	Disabled

Press: (5) if any features under this section have been enabled, the corresponding LED is illuminated or displayed upon LCD remote keypad.

**Note: To enable or disable any of the above options, toggle the corresponding key number. After entering options under this section press RESET to save changes and exit this location.**

### 2.15 Enable Quick Set

After enabling this option, the system maybe armed by pressing the set key for 3 seconds, this will begin the full set arming sequence without entering a user code.

Press: (1) zone 1 LED Flashing = Quick Set enabled.

Quick Set  
Enabled

**Note: If this function is enabled the installation will not comply with EN50130-1 requirements.**

### 2.16 Enable Special Switched Positive

The programmable Switched Positive is a unique feature of this control panel. In the factory default, the Switched Positive behaves in a normal manner (going high when the panel sets and low when the panel is switched off) for latching passive infra-red detectors. In the Special Switched Positive, this output can be used for impact sensors which require the power to be removed to reset them.

This output will give out up to 200mA as a positive supply to these detectors, which will behave in the manner described below.

When enabled the Special Switched Positive will be high, but when the panel is switched on Switched Positive goes low for 5 seconds, to reset the sensors. In the case of activation, even if the panel is reset, the power will remain on the impact sensors until the panel is switched back on again. This enables the information from the impact sensors to be retained.

Press: (2) zone 2 LED illuminated = Special Switched Positive enabled.

Special Set Pos  
Enabled

### 2.17 Enable Exit Strobe Flashes

When this function is enabled upon setting the system in full guard the strobe will give 5 flashes indicating system is set.

Press: (3) zone 3 LED illuminated = Strobe Exit Flashes enabled.

Strobe Flashes  
Enabled

### 2.18 Enable Engineer Reset

When this function is enabled, it prevents the user from resetting the system in the event of a Full alarm, PA or Tamper alarm activation. System can only be reset after entering the engineer code and pressing reset after the alarm has been silenced, by entering a valid user code.

Press: (4) zone 4 LED illuminated = Engineer Reset enabled.

Engineer Reset  
Enabled

### 2.19 Enable Engineer Code Burn InS

When this function is enabled, the engineer code will be retained in the memory and can not be changed even if the control panel is reset to factory default setting. In the event you forget your code PCB must be returned to supplier for repair.

Press: (5) zone 5 LED illuminated = Engineer Code Burn In enabled.

Code Burn In  
Enabled

### 2.20 Enable Final Set Push Button

The Final Set push button is used to Final Set the system after you have entered a code to arm the system by pressing the button during exit time it will stop the exit timer and immediately arm the system. The button should be installed on the outside of the protected area. During Day Mode and Part Guard it will act has a door bell giving a chime sound when pressed. You can not use a key switch to arm and disarm system if Final Set push button enabled.

Press: (6) zone 6 LED illuminated = Final Set Push Button enabled.

F/S Push Button  
Enabled

### 2.21 Enable Day LED

After enabling this option, the system Day LED will stay illuminated in Day Mode, when system is disarmed.

Press: (7) PA LED illuminated = Day LED stays illuminated enabled.

Day LED On  
Enabled

### 2.22 Entry Time Full Alarm

After enabling this option, the system will go into full alarm, if the entry time times out before a valid user code is entered.

Press: (8) Tamper LED stays illuminated = Entry Time Full Alarm enabled.

Entry Alarm  
Enabled

### 2.23 Switched Positive 0 Volts

After enabling this option, the Switched Positive will act in the following way. In armed mode and day mode 0 Volts, any alarm activation 12 Volts. Enable this feature if using a melcom AD1000 voice auto dialer.

Press: (9) Day LED Flashing = Switched Positive 0 Volts enabled.

Switched Pos 0V  
Enabled

**Note: Special Switched Positive & Normal Switched Positive will not work if this location is programmed.**

**If you have enabled any of these options, Quick Set, Day LED or Entry Time Full Alarm the system will not comply with current European alarm installation regulations. After entering options under section 5, press RESET key to exit this location.**

**2.24 Zone Description****Exit**

With the panel in DAY mode, if a valid user code is entered, the control panel will go into it's armed sequence. If any zone is at fault, the control panel will stop it's count down until that zone is cleared or omitted from the system, then will carry on arming the system.

**Entry**

When the panel is set and the entry zone is triggered, the entry timer will begin its countdown. During this period, the remote keypad will give a repeated beep and will beep faster when nearly timed out. If the time is allowed to elapse before any valid user code is entered, the control panel will go into alarm state. In this case the system needs to be Reset by pressing the RESET key after a valid user code has been entered to disarm the system.

**Walk Through**

This zone allows access without the alarm activating provided that the exit/entry zone as been activated before this zone.

**Instant**

This zone will create an alarm condition immediately if the control panel is set.

**24 Hour/Tamper**

A Tamper zone activation will only generate an internal alarm if the panel is in DAY mode. Triggering of the tamper zone when the panel is set will always give an external as well as internal alarm

**Personal Alarm (PA)**

Triggering of the personal attack (P.A.) zone will always cause a full alarm regardless of whether or not the panel is set.

**Fire Zone**

Triggering of the fire zone will operate internal & external sounders giving an intermittent sound, which is easily distinguished from the normal alarm sound.

**Note: Fire zones are intended as an extra feature to the alarm system and must not be regarded as a total fire protection system.**

**Final Set**

If a Entry/Exit zone is programmed as final set, upon arming the system and leaving by the Entry/Exit route the system will arm immediately once the Entry/Exit zone is clear without waiting for the exit timer to time out.

**Double Knock**

When a zone is programmed as a Double Knock zone, it requires two activations within 30 seconds before creating an alarm condition when panel is set.

**Disabled/Isolated**

When a zone is programmed has a Disabled/Isolated zone, it is ignored in the event of any activation. It allows the user to continue using the alarm system even if a fault has been discovered on one or more zones.

**2.25 Changing Full Guard Zone Type**

All zones can be changed to any status listed below:

Key No.	Function	Zone LED	Factory Default
1	Timed Entry/Exit	1	Zone 1
2	Walk Through	2	Zone 2
3	Instant	3	Zone 3,4,5,6
4	Personal Alarm (PA)	4	Zone 7/PA
5	24 Hour (Tamper)	5	Zone 8/Tamper
6	Fire	6	Clear
7	Final Set	PA	Clear
8	Double Knock	Tamper	Clear
9	Zone Disable/Isolated	Omit	Clear

## Contents

Changing a zone status:

Press: (6) All zone LEDs and PA flashing.

Enter zone number to be changed, the zone present status will be indicated by zone LEDs.

Press: (PROG) Enter required key function number, the corresponding key number is shown by zone LED.

Press: (RESET) Press: (RESET) to return back to engineer programming.

Zone Status  
Full Guard

### Example: Programming zone 5 as Entry/Exit zone

Press: (6) All zone LED's and PA flashing.

Press: (5) Zone 3 LED illuminates indicating zone 5 present status.

Press: (PROG) Press: (1) Zone 1 LED illuminates.

Press: (RESET)

Zone 5  
Instant

Zone 5  
Entry/Exit

Engineer  
Programming

To Change additional zones repeat steps B,C and D.

## 2.26 Changing Part Guard Zone Type

All Part Guard zones can be changed to any status listed below:

Key No.	Function	Zone LED	Factory Default
1	Timed Entry/Exit	1	Zone 1 & 3
2	Walk Through	2	Zone 2
3	Instant	3	Zone 4
4	Sleep Watch	4	Clear

**Note: If a zone is programmed as PA, 24hr, Fire or disabled in full guard it is not possible to change the status in part guard.**

### Sleep Watch Zone

Sleep watch zones are like interior zones and can be armed and disarmed using the SL6600 sleep watch keypad. Sleep Watch zones are armed in part guard after the system is set and by pressing the sleep Watch button for 1 second. Upon a sleep watch zone being activated it will not instantly go into full alarm, but start a delayed activation time has programmed. This gives the user time to disarm the system if a sleep watch zone is activated accidentally by enter their code into the keypad.

Changing a zone status:

Press: (7) All zone LEDs and PA flashing.

Enter zone number to be changed, the zone present status will be indicated by zone LED.

Press: (PROG) Enter required key function number, the corresponding key number is shown by zone LED.

Press: (RESET) Press: (RESET) to return back to engineer programming.

Zone Status  
Part Guard

### Example: Programming zone 4 as sleep watch zone

Press: (7) All zone LEDs and PA flashing.

Press: (4) Zone 3 LED illuminates indicating zone 4 present status.

Press: (PROG) Press: (4) Zone 1 LED illuminates.

Press: (RESET)

Zone 4  
Instant

Zone 4  
Sleep Watch

Engineer  
Programming

To Change additional zones repeat steps B,C and D.

## 2.27 Changing Engineering Code

For security reasons it is best to use your own ENGINEER CODE rather than use the factory pre-set code.

Enter New Code  
Engineer

Press: (8) Zones 1,2,3,4, LEDs illuminated.  
Type in new engineer code.

Engineer  
Programming

After entering the forth digit the panel will give an acceptance tone and return to ENGINEER PROGRAMMING MODE, the new code will now be operative

## 2.28 Enable Service Timer

To set service timer from engineer programming mode, enter one of the following options:

Press: (9) Zone LEDs will show present status.

Service Timer  
Disabled

Press: (1) Zone LEDs not illuminated = No service timer.

Service Timer  
6 Weeks

Press: (2) Zone 1 LEDs illuminates = 6 weeks timer.

Service Timer  
6 Months

Press: (3) Zone 2 LEDs illuminates = 6 months timer.

Service Timer  
12Months

Press: (4) Zone 3 1LEDs illuminates = 12 months timer (12.5 months +/- 1%).

Service Timer  
100 Events

Press: (5) Zone 4 LEDs illuminates = 100 event timer (arming anddisarming is an event).

Service Timer  
200 Events

Press: (6) Zone 5 LEDs illuminates = 200 event timer.

Service Timer  
800 Events

Press: (7) Zone 6 LEDs illuminates = 800 event timer.

Engineer  
Programming

Press: (RESET) After entering required service timer.

Once the pre-set service time has timed out, the Tamper LED will flash and continue until the engineer programming code has been entered. If the service timer is required again then the service timer must be reprogrammed. The control panel will continue to function once the service timer has timed out.

**Note: Entering engineer programming, will not reset the service timer once set, unless service timer has time out.**

## 2.29 Setting System Date

The date will only be displayed if the system is fitted with a ST5000 remote LCD keypad. In the event of an alarm activation, the date is stored in the memory log.

Set Data  
00-00-00

Press: (9) (8)

Enter date using 2 digits to represent Year, Month and Day. The year should be entered first, followed by month and day, date will be displayed on LCD DD-MM-YY.

Engineer  
Programming

After entering Day, it will revert back to engineer programming. To check date entered, enter this location again, re-enter date if wrong.

**Note: In the event of complete power failure, the Date & Time must be RESET.**

## 2.30 Setting System Time

The time will only be displayed if the system is fitted with a K6600 remote LCD keypad. In the event of an alarm activation, the time is stored in the memory log. The time is displayed in 24 hour format.

Press: (9) (9)

Enter time using 2 digits to represent Hours, Minutes, HH-MM

After entering minutes, it will revert back to engineer programming. To check time entered you must enter this location again, re-enter time if wrong.

Set Time  
00-00

Engineer  
Programming

## 2.31 Exiting Engineer & User Programming

Press: (RESET) to exit engineer programming, Tamper LED on

Press: (RESET) to return to day mode, Day LED Flashing

## 2.32 Reset Control Panel to Factory Default Settings (NVM Reset)

To reset the NVM, power down the panel and short out the NVM pins, then power up and remove the short. This will reset panel to factory set condition.

## 2.33 Reset Control Panel without Losing Engineer Log

From Engineer Programming mode

Press: (MEM)

This will reset the panel to factory set conditions, but will not lose the engineers log.

<b>3.00 Engineer Reference Guide</b>					
		<b>User Programming (PA, Tamper and Day LEDs On)</b>		<b>User Manual</b>	<b>Page</b>
<b>Press:</b>	<b>PROG</b>	<b>All Zone and Day LEDs illuminated</b>			<b>11</b>
<b>Press:</b>	<b>1234</b>	<b>Tamper and Day LEDs Stay illuminated</b>			
<b>Press:</b>	<b>0</b>	<b>System Test Mode</b>			<b>14</b>
Enter:	1	Strobe Test			
Enter:	2	Bell Test			
Enter:	3	High Sounder Internal Keypad			
Enter:	4	Low Sounder Internal Keypad			
Enter:	5	Walk Test (PA and Tamper Give Same Tone)			
Enter:	0	Exit Test Mode			
<b>Press:</b>	<b>2</b>	<b>To Set Second User Code</b>		<b>Default : 0000</b>	<b>11</b>
<b>Press:</b>	<b>3</b>	<b>To Set Third User Code</b>		<b>Default : 0000</b>	<b>11</b>
<b>Press:</b>	<b>4</b>	<b>To Set Forth User Code</b>		<b>Default : 0000</b>	<b>11</b>
<b>Press:</b>	<b>5</b>	<b>To Set Fifth User Code</b>		<b>Default : 0000</b>	<b>11</b>
<b>Press:</b>	<b>6</b>	<b>To Set Sixth User Code</b>		<b>Default : 0000</b>	<b>12</b>
<b>Press:</b>	<b>7</b>	<b>To Set Secure Zones = Secure Zone LED Flashing</b>		<b>Press: RESET</b>	<b>12</b>
<b>Press:</b>	<b>8</b>	<b>To Set New Master User Code</b>		<b>Default: 1234</b>	<b>11</b>
<b>Press:</b>	<b>9</b>	<b>To Set Chime Zones (PA and Tamper LED illuminated)</b>		<b>Press: RESET</b>	<b>13</b>
<b>Press:</b>	<b>RESET</b>	<b>Exit User Programming</b>			<b>13</b>
<b>Press:</b>	<b>MEM</b>	<b>Memory Recall Last Activation Shown First</b>		<b>Press: RESET</b>	<b>9</b>
		<b>Engineer Programming</b>		<b>Installation Manual</b>	<b>Page</b>
<b>Press:</b>	<b>PROG</b>	<b>All Zone and Day LEDs illuminated</b>			<b>13</b>
<b>Press:</b>	<b>1234</b>	<b>Master User Code Tamper and Day LEDs Stay illuminated</b>		<b>Default: 1234</b>	
<b>Press:</b>	<b>PROG</b>	<b>All Zone and Day LEDs illuminated</b>			
<b>Press:</b>	<b>9999</b>	<b>Engineer Programming Code (PA and Day LEDs illuminated)</b>		<b>Default: 9999</b>	
<b>Press:</b>	<b>1</b>	<b>Set Exit Time in Seconds</b>		<b>Default: 30 Seconds</b>	<b>14</b>
<b>Press:</b>	<b>2</b>	<b>Set Entry Time in Seconds</b>		<b>Default: 30 Seconds</b>	<b>14</b>
<b>Press:</b>	<b>3</b>	<b>Set Bell Rest Time in Minutes</b>		<b>Default: 15 Minutes</b>	<b>14</b>
<b>Press:</b>	<b>41</b>	<b>Set Part Guard Exit Time in Seconds</b>		<b>Default: 5 Seconds</b>	<b>15</b>
<b>Press:</b>	<b>42</b>	<b>Disable/Isolate Zones in Part Guard</b>		<b>Press: RESET</b>	<b>15</b>
<b>Press:</b>	<b>43</b>	<b>Set Sleep Watch Activation Zone Delay Time in Seconds</b>		<b>Default: 15 Seconds</b>	<b>15</b>
<b>Press:</b>	<b>44</b>	<b>Enable Sleep Watch Zones Automatic Rearm, Toggle Key 4</b>		<b>Press: RESET</b>	<b>15</b>
<b>Press:</b>	<b>45</b>	<b>Set Sleep Watch Zones Automatic Rearm Time</b>		<b>Default: 15 Minutes</b>	<b>15</b>
<b>Press:</b>	<b>46</b>	<b>Enable Sleep Watch to Arm/Disarm Part Guard Toggle Key 6</b>		<b>Press: RESET</b>	<b>16</b>
<b>Press:</b>	<b>47</b>	<b>Enter Installer Message Displayed on Remote LCD Keypad</b>		<b>Press: RESET</b>	<b>16</b>
<b>Press:</b>	<b>48</b>	<b>Enter Zone Description Displayed on Remote LCD Keypad</b>		<b>Press: RESET</b>	<b>16</b>
<b>Press:</b>	<b>5</b>	<b>Miscellaneous Section 1</b>			
Enter:	1	Enable User Quick Set	Zone 1 LED On = Enabled	Toggle Key 1	18
Enter:	2	Enable Special Switched Positive	Zone 2 LED On = Enabled	Toggle Key 2	18
Enter:	3	Enable Strobe Exit Flashes	Zone 3 LED On = Enabled	Toggle Key 3	18
Enter:	4	Enable Engineer Reset	Zone 4 LED On = Enabled	Toggle Key 4	18
Enter:	5	Enable Engineer Code Burn In	Zone 5 LED On = Enabled	Toggle Key 5	18
Enter:	6	Enable Final Set Push Button	Zone 6 LED On = Enabled	Toggle Key 6	18

## Contents

Enter:	7	Enable LED Day Mode	PA LED On =Enabled	Toggle Key 7	19
Enter:	8	Entry Zone Full Alarm	Tamp LED On = Enabled	Toggle Key 8	19
Enter:	9	Switched Positive 0 Volts	Day LED On = Enabled	Toggle Key 9	19
<b>After Entering Options Press: RESET</b>					
<b>Press:</b>	<b>6</b>	<b>Change Zone Status Full Guard: Enter Zone Number Press</b>			<b>20</b>
Enter:	1	Timed Exit/Entry	LED Indication= Zone 1	Default: Zone 1	
Enter:	2	Walk Through	LED Indication= Zone 2	Default: Zone 2	
Enter:	3	Instant	LED Indication= Zone 3	Default: Zone 3-6	
Enter:	4	Personal Alarm (PA)	LED Indication= Zone 4	Default: Zone PA/7	
Enter:	5	24 Hour	LED Indication= Zone 5	Default: Zone Tamp	
Enter:	6	Fire	LED Indication= Zone 6	Default: None	
Enter:	7	Final Set	LED Indication= Zone PA	Default: None	
Enter:	8	Double Knock	LED Indication= Zone Tamp	Default: None	
Enter:	9	Disable/Isolate	LED Indication= Zone Omit	Default: None	
<b>After Entering Option Press: RESET</b>					
<b>Press:</b>	<b>7</b>	<b>Change Zone Status Part Guard: Enter Zone Number Press</b>			<b>21</b>
Enter:	1	Timed Exit/Entry	LED Indication= Zone 1	Default: Zone 1,3	
Enter:	2	Walk Through	LED Indication= Zone 2	Default: Zone 2	
Enter:	3	Instant	LED Indication= Zone 3	Default: Zone 4,5,6	
Enter:	4	Sleep Watch	LED Indication= Zone 4	Default: None	
<b>After Entering Option Press: RESET</b>					
<b>Press:</b>	<b>8</b>	<b>Set New Engineer Programming Code</b>		<b>Default: 9999</b>	<b>21</b>
<b>Press:</b>	<b>9</b>	<b>Service Timer Section</b>			<b>22</b>
Enter:	1	No Service Timer	LED Indication= None		
Enter:	2	6 Weeks Service Timer	LED Indication= Zone 1		
Enter:	3	6 Months Service Timer	LED Indication= Zone 2		
Enter:	4	12 Months Service Timer	LED Indication= Zone 3		
Enter:	5	100 Events	LED Indication= Zone 4		
Enter:	6	200 Events	LED Indication= Zone 5		
Enter:	7	800 Events	LED Indication= Zone 6		
<b>After Entering Option Press: RESET</b>					
<b>Press:</b>	<b>98</b>	<b>Set Date</b>			<b>22</b>
<b>Press:</b>	<b>99</b>	<b>Set Time</b>			<b>22</b>
<b>Press:</b>	<b>MEM</b>	<b>Reset Panel To Factory Default Setting Without Losing Engineer Log</b>			<b>23</b>
<b>Exit Engineer Programming</b>					
Press:	RESET	Returns to User Programming			
<b>Exit User Programming</b>					
Press:	RESET	Returns to Day Mode			
<b>Reset Panel to Factory Default Settings</b>					
		Short NVM Reset Pins, Disconnect Power, Return Power To The Unit and Remove Short From NVM Reset Pins.			<b>23</b>

<b>3.01 Engineer Programming Record</b>		
<b>Function</b>	<b>Factory Settings</b>	<b>Installation Settings</b>
Entry Time	30 Seconds	
Exit Time	30 Seconds	
Alarm Time	15 Minutes	
<b>Full Guard</b>		
Zone 1	Timed Entry/Exit	
Zone 2	Walk Through	
Zone 3	Instant	
Zone 4	Instant	
Zone 5 Zone Expansion Module ST5008	Instant	
Zone 6 Zone Expansion Module ST5008	Instant	
Zone 7 Zone Expansion Module ST5008	Personal Alarm(P.A.)	
Zone 8	Tamper	
Fire Zones	Clear	
Final Set Zones	Clear	
Double Knock Zones	Clear	
Disabled/Isolated Zones	Clear	
Sleep Watch Zones Delay Activation Time	15 Seconds	
Sleep Watch Zones Automatic Rearm	Disabled	
Sleep Watch Zones Automatic Rearm Time	15 Minutes	
Sleep Watch Keypad Arm/Disarm Part Guard Arming	Disabled	
Installer Message	Melcom	
Quick Set	Disabled	
Special Switched Positive	Disabled	
Exit Strobe Flashes	Disabled	
Engineer Reset	Disabled	
Engineer Code Burn In	Disabled	
Final Set Push Button	Enabled	
LED Day Mode Illuminated	Enabled	
Entry Timed Out Full Alarm	Disabled	
Switched Positive 0 Volts Day & Armed Mode	Disabled	
Date	Clear	
Time	Clear	
<b>Part Guard</b>	<b>Euard</b>	
Set Time	5 Seconds	
Zones Disabled/Isolated	None	
Zone 1	Timed Entry/Exit	
Zone 2	Walk Through	
Zone 3	Timed Entry/Exit	
Zone 4	Instant	
Zone 5 Zone Expansion Module ST5008	Instant	
Zone 6 Zone Expansion Module ST5008	Instant	
Zone 7/PA Zone Expansion Module ST5008	Personal Alarm(P.A.)	



## 4.00 Electrical and Technical Specifications

### Power Supply

<b>Primary Mains Supply Voltage Rating:</b>	230Vac/115Vac ( $\pm 10\%$ )
<b>Secondary Input Voltage Rating:</b>	18.1Vac
<b>Maximum Total Current Rating:</b>	900mA
<b>Rechargeable Backup Battery:</b>	12V Sealed Lead Acid 1.2 Ah

### Environmental

<b>Operating Temperature:</b>	-10°C (14°F) to 50°C (122°F)
<b>Storage Temperature:</b>	-20°C (-4°F) to 60°C (140°F)
<b>Maximum Humidity:</b>	95% non-condensing
<b>EMC Environment:</b>	Residential/Commercial

### Electrical

<b>Current Consumption:</b>	
Quiescent Current:	<25mA
Alarm Current:	<150mA
<b>Auxiliary Voltage Output:</b>	Regulated 13.5Vdc
<b>Switched Positive Voltage:</b>	
When Low:	1.0Vdc
When High:	12Vdc
<b>Bell Voltage Output:</b>	12Vdc
<b>Speaker Voltage Output:</b>	12Vdc
<b>Strobe Voltage Output:</b>	12Vdc
<b>Internal Sounder:</b>	0.25Watts 32 Ohms
<b>Positive Loop Threshold (Zones 1-7/PA):</b>	
Minimum Open Resistance:	70k $\parallel$ $\Omega$
Maximum Closed Resistance:	10k $\parallel$ $\Omega$
<b>Negative Loop Threshold (System Tamper):</b>	
Minimum Open Resistance:	110k $\parallel$ $\Omega$
Maximum Closed Resistance:	20k $\parallel$ $\Omega$

### Physical

<b>Dimensions:</b>	260mm X 225mm X 80mm
<b>Housing Material ST5000:</b>	Inflammable 94VO High Impact ABS Plastic
<b>Weight ST5000:</b>	1.30Kgs

### K6600 Remote LCD Keypad

<b>Electrical:</b>	
<b>Operating Voltage:</b>	12Vdc
<b>Quiescent Current LCD Back Light Off:</b>	16.7mV
Current LCD Back Light On:	90mA
Current in Alarm	70mA
<b>Wiring:</b>	6 Core Multi-stranded Cable 7 x 0.20m2
<b>Dimensions :</b>	135mm X 108mm X 80mm
<b>Housing Material:</b>	ABS Plastic
<b>Weight:</b>	0.30Kgs

### SL6600 Sleep Watch Remote Keypad

<b>Electrical:</b>	
<b>Operating Voltage:</b>	12Vdc
<b>Quiescent Current :</b>	16.7mV
<b>Wiring:</b>	4 Core Multi-stranded Cable 7 x 0.20m2
<b>Dimensions :</b>	135mm X 108mm X 80mm
<b>Housing Material:</b>	ABS Plastic
<b>Weight:</b>	0.20Kgs





