

# ES34/ES34E

## SECURITY MOTION SENSOR

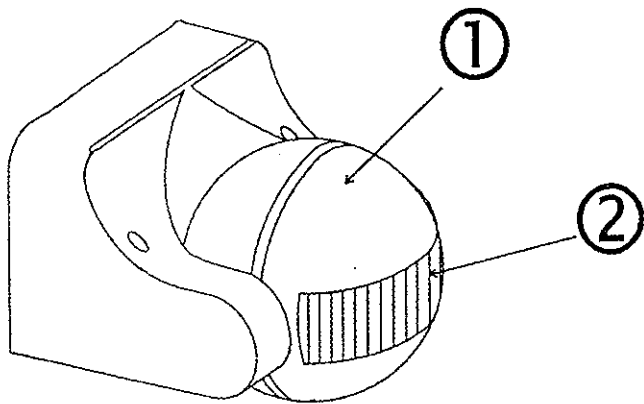

- ① PIR (Motion Sensor )
- ② PIR Lens

### INTRODUCTION

Your EVERSPRING SECURITY MOTION SENSOR is a fully automatic outdoor security/courtesy light controller capable of controlling up to 1100W of lighting. At night, the built-in passive infrared (PIR) motion sensor turns on the connected lighting system when it detects motion in its coverage area. During the day, the built-in photocell saves electricity by deactivating the lights. An adjustable timer lets you select how long the light stays on after activation.

Two operation options - let you choose automatic operation or manual override based on the ambient light level.

Note : Read this entire manual before you start to install the system.

### SAFETY PRECAUTIONS

- Do not install when it is raining.
- Be sure to switch off power source before installing.
- Make sure that the power wiring comes from circuit with a suitable fuse or circuit breaker.
- The unit can be installed only horizontally (see the FIGURE 1a), not vertically (see the FIGURE 1b) as shown in the below drawing.

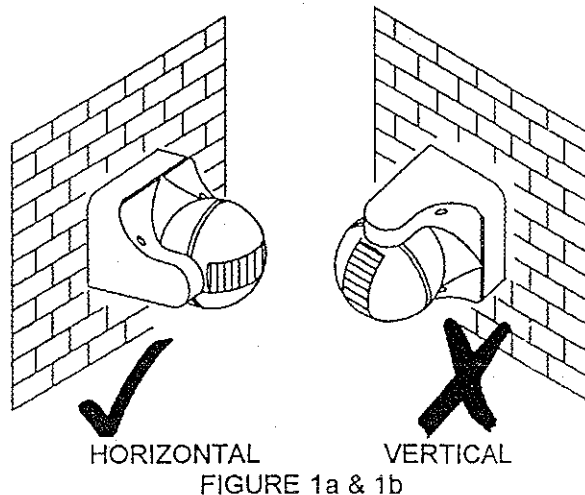

### IMPORTANT

Some local building codes may require installation of this product by a qualified electrician.

Check your local codes as they apply to your situation. If the house wiring is of aluminum, consult with an electrician about proper wiring methods.

Maintenance or repairing work such as replacing current-fuse shall be done by qualified electrician or technician.

Before proceeding with the installation, TURN OFF THE POWER TO THE LIGHTING CIRCUIT AT THE CIRCUIT BREAKER OR FUSE BOX TO AVOID ELECTRICAL SHOCK.

### CHOOSING A MOUNTING LOCATION

- For the best results, fix your sensors on a solid surface. For wall mounting, 1.8~2M above the ground is needed. For ceiling mounting, 2.5~4M above the ground is required.
- For outdoor installation, a location under eaves is preferable.
- Avoid aiming the motion sensor at pools, heating vents, air conditioners or objects which may change temperature rapidly.
- Do not allow sunlight to fall directly on the front of unit.
- Try to avoid pointing the unit at trees or shrubs or where the motion of pets may be detected.

- Prior to mounting, keep in mind that the motion sensor is most sensitive to the motion, which is across the detection field and less sensitive to the motion, which moves directly towards the detector. (FIGURE 2)

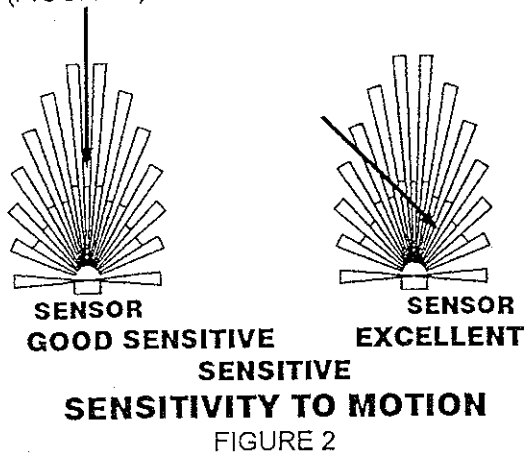

Note : The detection angle of ES34 can come up to 180°. However to reduce or localize its detection coverage, use the small plastic slip(s) provided to cover up part(s) of the LENS, thus reducing its detection angle. (FIGURE 6)

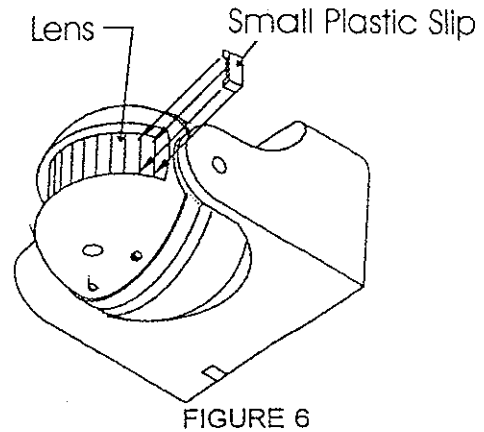

## INSTALLATION

To facilitate installation, it is essential to get a drill and a screwdriver ready. Select a location for the unit based on the coverage angles shown in FIGURE 3.

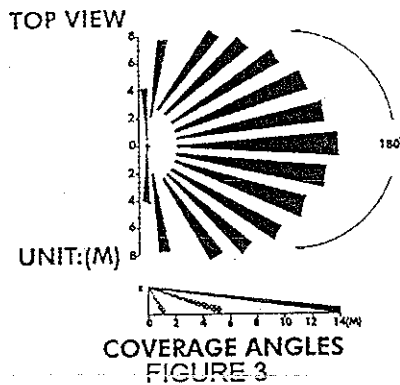

Install a wall switch adjacent to the power source. (FIGURE 4 & 5) This helps you operate AUTO and MANUAL OVERRIDE with ease. See page 4 for further information.

### Type I (ES34):

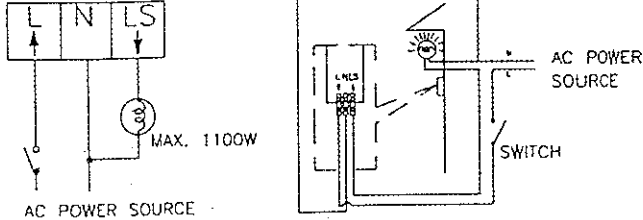

FIGURE 4

### Type II (ES34E):

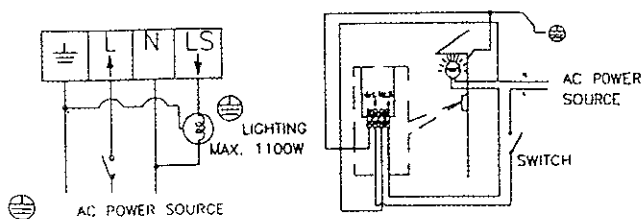
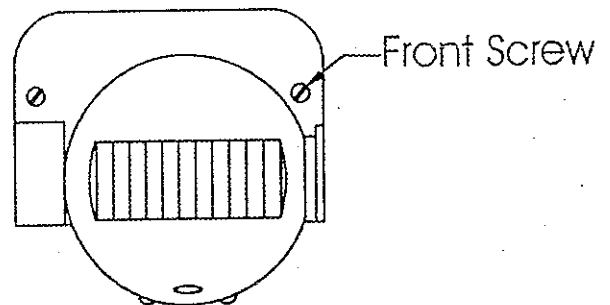

FIGURE 5

## WIRING INSTRUCTION

- (1) Switch off the power source or wall switch.
- (2) Unscrew two front screws to detach the base cover from the unit. (FIGURE 7)



- (3) Make use of the base cover as a template to mark the position of two screw holes on the wall. Drill the wall and screw the base cover onto the wall using suitable plastic wall plugs and screws provided. (FIGURE 8).

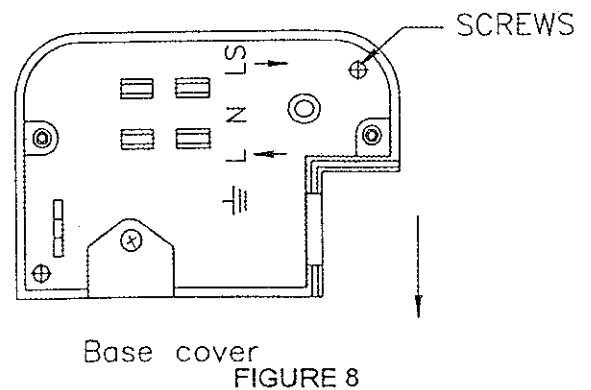

- (4) Strip approximately 6-8mm insulating part of the wires from the power cord. Before connection, run the wires through the rubber seal provided.

Note: The power cord must meet H05RN-F, 1.0mm<sup>2</sup> requirement.

- (5) For power wire connection,  
**Type I (ES34):**  
 Connect the BROWN wire (Live wire) to the terminal block "L" mark.

Connect the BLUE wire (Neutral wire) to the terminal block "N" mark. (FIGURE 9)

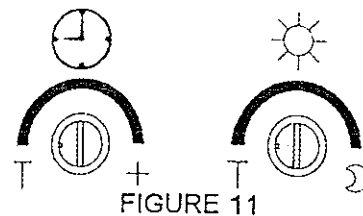
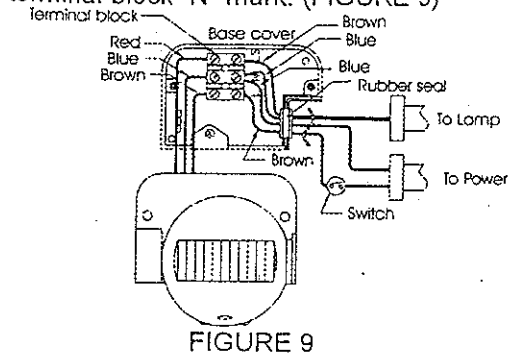

FIGURE 11

- Turn on the wall switch. The light will turn on for about 1 minute to warm up. Then it turns off.
- Walk through the detection area. The light turns on when you move and turns off when you stop. Wait for the light to turn off before moving again to test the sensor.
- Adjust the motion sensor to cover the desired detection area. For a smaller coverage area, point the sensor down; for a larger coverage area, point the sensor up.

**Type II (ES34E):**

Connect the BROWN wire (Live wire) to the terminal block "L" mark.

Connect the BLUE wire (Neutral wire) to the terminal block "N" mark.

Connect the YELLOW/GREEN (Ground wire) to the terminal block "⏏" mark. (FIGURE 10)

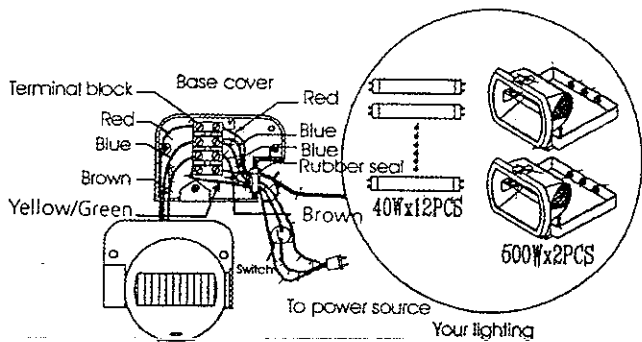

FIGURE 10

## (2) TIME ADJUSTMENT

The TIME adjustment controls how long the light will stay on after the motion has been detected.

Turn the TIME control knob clockwise to increase (up to about 12 minutes) how long the lights stay on or anti-clockwise to decrease (down to about 5 seconds) the time delay. (FIGURE 12)

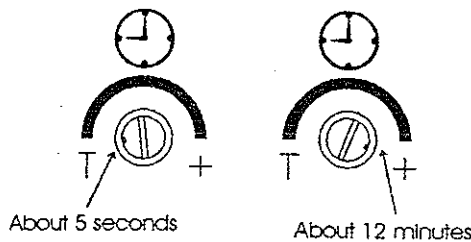

FIGURE 12

- (6) For lamp wire connection,  
 Connect the 'BLUE' wire to the terminal block 'N' mark.

Connect the 'BROWN' wire to the terminal block 'LS' mark.

Note: For the ES34E, besides the above mentioned two points, you have to connect the 'YELLOW/GREEN' wire to the terminal block

'⏏' mark.

- (7) Fix the pre-wired terminal block to the boss of base cover tightly. Place and fix the rubber seal to the wire outlet.

- (8) Refit and screw the unit to the base cover.

## SETTING THE LIGHTING SYSTEM

### (1) TEST MODE

- Turn the Lite control and the Time control anti-clockwise to the edge – the TEST position (FIGURE 11)

### (3) LITE ADJUSTMENT

The LITE adjustment determines at what light level the lighting system will start operating when you set the sensor to automatic operation.

Provisionally turn the LITE control knob to the edge clockwise at the moon (dusk) position (FIGURE 13). In this provisional setting mode, the Motion Sensor remains inactive during daylight. At dusk when you find it is the LUX level desired for operation, simply set the LITE control knob to the position which becomes active as daylight declines.

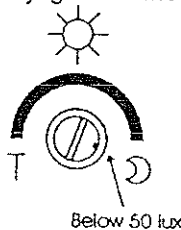

FIGURE 13

Note : Water-resistance function only available when Time and Lite control knobs face down. (FIGURE 14)

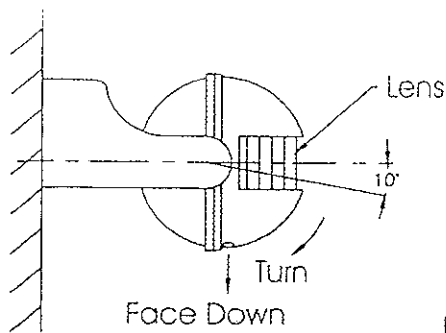

FIGURE 14

## OPERATION

By using wall switch to your ES34/ES34E, you can easily select one of two modes of operation: automatic operation and manual override.

### (1) AUTOMATIC OPERATION

Turn on the wall switch. When the sensor detects motion, the light automatically turns on. The built-in photocell turns the sensor off and on according to the light level selected by the Lite adjustment.

### (2) MANUAL OVERRIDE

To keep the light on regardless of the motion, you can override the automatic operation. Turn the wall switch off and on within 2 seconds.

In Manual Override mode, the light will remain on.

Users can also set the motion sensor back to Auto operation by turning off the wall switch for at least 10 seconds and then turn it back on.

## TROUBLESHOOTING

### Light does not turn on

- Confirm that you have made a correct "wiring connection".
- Make sure that the bulbs have not burned out.
- Check if the fuse has not burned out.  
Note: For checking or replacing current fuse, it must be done by qualified electrician or technician.

### Light remains on

- Make sure the wiring connection is correct.
- If you set the system to manual override, remember that you must turn the wall switch off for at least 10 seconds to switch the sensor to automatic operation and turn off the lights.
- Check if the TIME setting is correct.

## SPECIFICATIONS

Detection Method	Passive infrared
Power Requirement	AC 220 - 240V/ 50Hz
Lighting Load (Incandescent)	Max. 1,100W Tungsten
Fuse Rating	6.3A, Flink : F6.3L250V
Standby Current	30mA
Operating Current	35mA
Power Cord Requirement	H05RN-F, 1.0mm <sup>2</sup>
<b>Sensor Power</b>	
Protection Class	Class II
Waterproof	IP44
<b>Operating</b>	
Temperature	-20° C to +40° C
Detection Range	12M at 20° C
<b>Sensor Adjustments</b>	
Detection Angle	180°
Swiveling Angle	Vertical 220°
Warm Up Time	About 1 minute
Time Adjustment	From 5± 3 seconds to 12± 3 minutes
Lux Adjustment	From 0 Lux to 1,000Lux.
Mounting Height	1.8 to 2M (5.9 to 6.6 Feet) Wall Mount 2.5 to 4M (8.2 to 13.2 Feet) Ceiling Mount
Switch Function	Off/Auto/Manual Override