

ES73

MOTION SENSOR BULKHEAD LIGHT

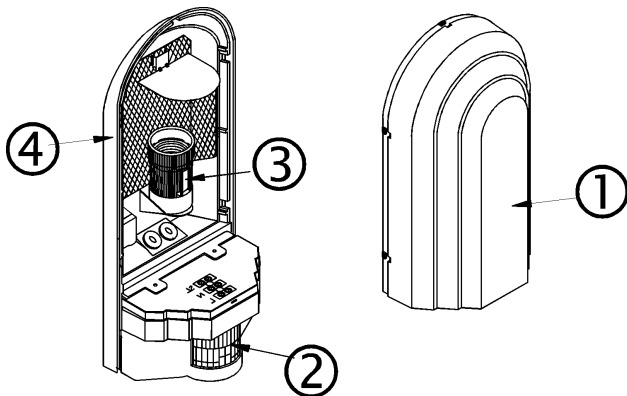

- ① Lamp Shade
- ② PIR Motion Sensor
- ③ Bulb Holder
- ④ Bottom Housing

INTRODUCTION

Your EVERSPRING MOTION SENSOR BULKHEAD LIGHT is a unique lighting system with the capability of controlling additional lighting for your home or business. At night, the built-in passive infrared (PIR) motion sensor turns on the floodlight when it detects motion in its coverage area. During the day, the built-in photocell sensor saves electricity by deactivating the floodlight. An adjustable timer lets you select how long the light will stay on after activation. Sensitivity adjustment lets you change the detection distance according to the temperature. Two operation options let you choose: Automatic Operation or Manual Override.

Note: Read this entire manual before you start to install the system.

SAFETY PRECAUTIONS

- Do not install when it is raining.
- Be sure to switch off power source before installing.
- Make sure that the power wiring comes from circuit with an external 16A miniature circuit breaker for the short circuit protection or a suitable fuse.
- Keep minimum 0.8m away from the lighted objects.
- The unit can be installed only vertically (FIGURE 1a), not horizontally (FIGURE 1b).

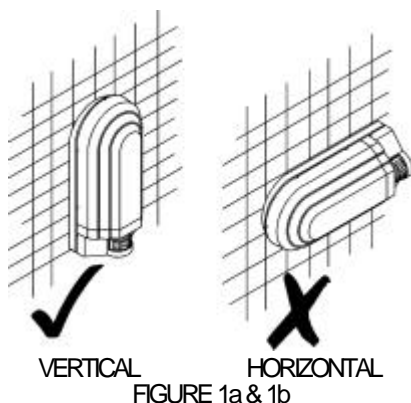

FIGURE 1a & 1b

IMPORTANT

Some local building codes may require installation of this product by a qualified electrician.

Check your local codes as they apply to your situation. If the house wiring is of aluminum, consult with an electrician about proper wiring methods.

Maintenance or repairing work such as replacing current fuse shall be done by a qualified electrician or technician.

Before proceeding with the installation, TURN OFF THE POWER TO THE LIGHTING CIRCUIT AT THE CIRCUIT BREAKER OR FUSE BOX TO AVOID ELECTRICAL SHOCK.

CHOOSING A MOUNTING LOCATION

- For the best results, fix your motion sensor light on a solid surface, 1.8~2.5M above the ground.
- For outdoor installation, a location under eaves is preferable.
- Avoid aiming the motion sensor at pools, heating vents, air conditioners or objects that may change temperature rapidly.
- Do not allow sunlight to fall directly on the front of unit.
- Try to avoid pointing the unit at trees or shrubs or where the motion of pets may be detected.
- Prior to mounting, keep in mind that the motion sensor is more sensitive to the motion, which is across the detection field and less sensitive to the motion, which moves directly towards the detector. (FIGURE 2)

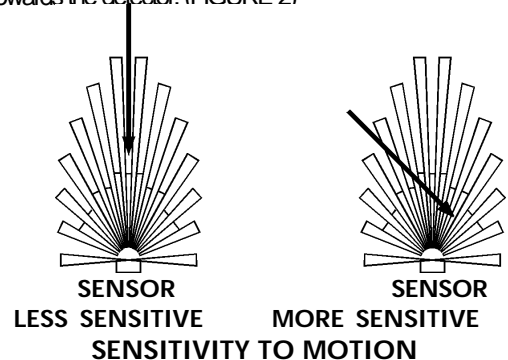

FIGURE 2

BULB INSTALLATION

- (1) Remove the lamp shade.
- (2) Insert an incandescent or a PL bulb to the bulb holder by turning clockwise.
- (3) Do not use an incandescent bulb rated higher than 60W or alternatively 13W for a PL bulb.

INSTALLATION

To facilitate installation, it is essential to get a drill and a screwdriver ready. Select a location for the unit based on the coverage angles shown in FIGURE 3.

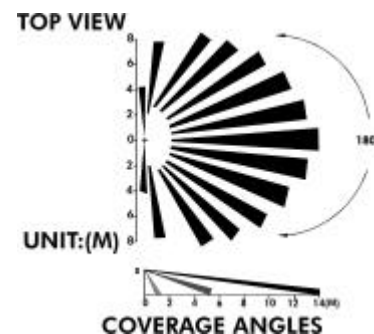

FIGURE 3

Install a wall switch adjacent to the power source. (FIGURE 4). This will help you operate this motion sensor light with ease. See OPERATION for further information.

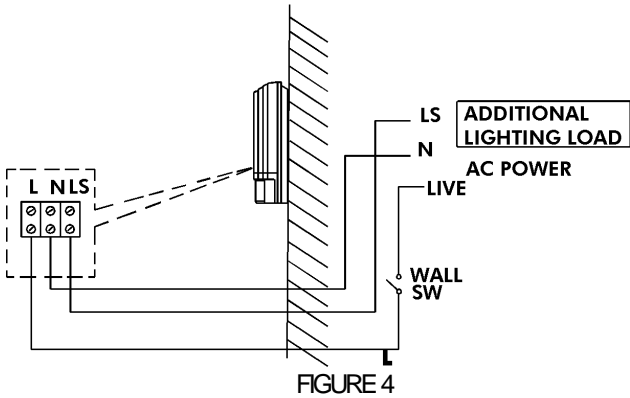

FIGURE 4

WIRING INSTRUCTION

- (1) Switch off the power source or wall switch.
- (2) Use a flat screwdriver to hinge off the lamp shade from its bottom housing (FIGURE 5).

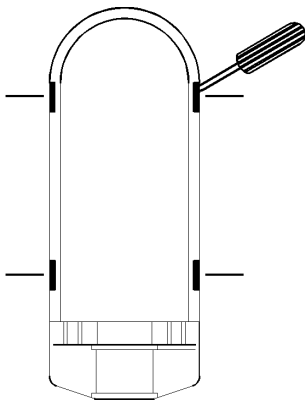

FIGURE 5

- (3) Use a screwdriver to break a small hole on the cable gasket and route the power cord along the groove to go through the cable gasket hole (FIGURE 6a & 6b).

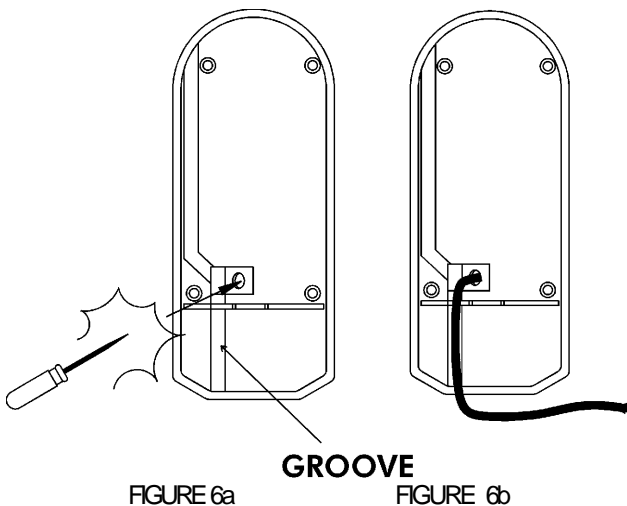

FIGURE 6a

FIGURE 6b

Note: The power cord must meet H05RNHF, 3G 1.0mm² requirement.

- (4) The terminal block is put in a cavity besides the bulb holder. Unscrew the screw from the terminal block cover and remove the terminal block cover (FIGURE 7a & 7b).

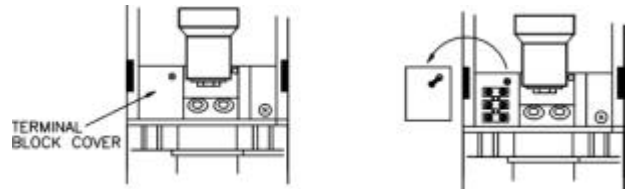

FIGURE 7a

FIGURE 7b

- (5) Connect the BROWN wire to terminal block "L" mark. Connect the BLUE wire to terminal block "N" mark.

Note: Under the circumstances of not connecting to extra lighting load, the unit housing can either fit a 60W incandescent bulb or a 13W PL bulb. However, it can still commute additional lighting load up to 1,000W incandescent / 500W fluorescent. For instance, connection to either 2 pcs of 500W halogen bulbs or 12pcs of 40W fluorescent bulbs is appropriate. Those extra lighting devices may be added as follows (FIGURE 8).

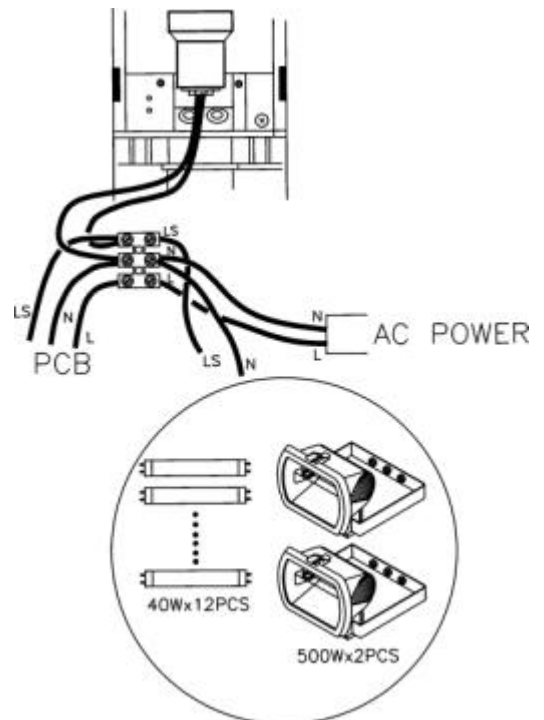

FIGURE 8

Connect the BROWN wire to terminal block "LS" mark. Connect the BLUE wire to terminal block "N" mark.

- (6) Drill two holes on the bottom housing using the two screws provided to fix the unit to the wall (FIGURE 9).

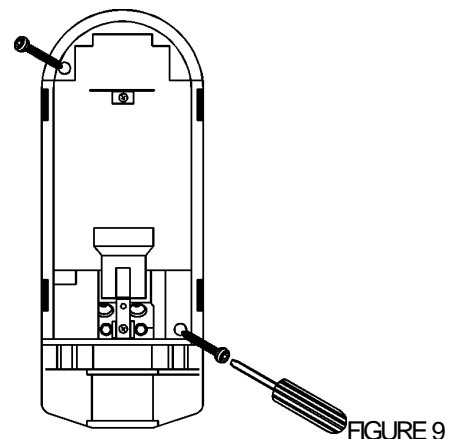

FIGURE 9

Note: Ensure that the position of two screws to fix on the wall should be inserted diagonally and followed exactly according to the drawings shown.

SETTING THE LIGHTING SYSTEM

(1) TEST MODE

- Make sure that the black label is stuck on photocell sensor (FIGURE 10).

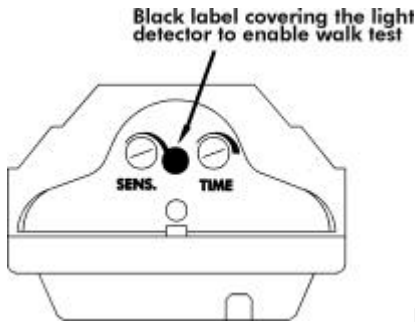

FIGURE 10

- Set the SENS. knob in the mid position and TIME control knob to fully anti-clockwise to the edge.
- Turn on the power or wall switch.
- Wait for 1 minute to warm up the device, then start testing. Walk through the detection area. The light turns on when you move and turns off when you stop. Wait for the lights to turn off before moving again to test the sensor.
- Adjust the motion sensor to cover the desired detection area. For a smaller coverage area, point the sensor down; for a larger coverage area, point the sensor up.
- Take off the black label from photocell sensor. The unit now is in Automatic Operation mode.

(2) TIME ADJUSTMENT

The TIME adjustment controls how long the light will stay on after the motion has been detected.

Turn the TIME control knob clockwise to increase (up to about 8 minutes) how long the lights stay on or anti-clockwise to decrease (down to about 5 seconds) the time delay. (FIGURE 11)

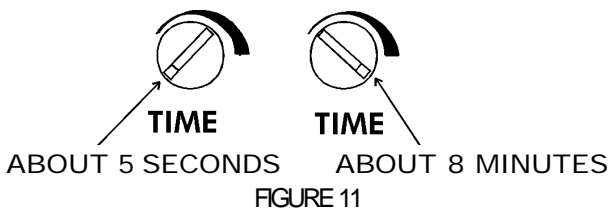

FIGURE 11

(3) SENS. ADJUSTMENT

The motion sensor's sensitivity adjustment controls "detection distance". It can be adjusted to compensate for seasonal variations in temperature and to reduce unwanted triggering. The optimum sensitivity can be achieved by setting the SENS. control knob initially to its mid position and then adjusting the control knob clockwise to increase (up to 12 meters) the detection distance or anti-clockwise to decrease (down to 3 meters) the detection distance.

OPERATION

By using the wall switch connected to your motion sensor light, you can easily select one of two modes of operation: Automatic Operation and Manual Override.

(1) AUTOMATIC OPERATION

Turn on the wall switch. The light will be automatically on when the motion sensor detects motion and will be off after the motion is stopped or out of detection range. The unit is active only from dusk to dawn.

(2) MANUAL OVERRIDE

To keep the light on regardless of the motion, you can override the Automatic Operation. Turn the wall switch off and on twice within 4 seconds. The interval between the first and second operation must be within 0.5 - 2 seconds.

In Manual Override mode, the light will remain on for around 4 ~ 6 hours despite no motion; then the light will turn off and the motion sensor will be back to Auto Operation mode automatically.

Users can also set the motion sensor back to Auto Operation by turning off the wall switch for at least 10 seconds and then turn it back on.

TROUBLE SHOOTING

Light does not turn on:

- Confirm that you have made a correct "wiring connection".
- Make sure that the bulb has not burned out.

Light remains on:

- Make sure the wiring connection is correct.
- If you set the motion sensor to Manual Override, remember that you must turn the wall switch off for at least 10 seconds before switch the motion sensor on back to Automatic Operation.
- Check if the TIME setting is correct.

SPECIFICATIONS

Power Requirement	AC 220 ~ 240V / 50Hz
Power Cord Requirement	H05RNF, 3G, 1.0mm ²
Lighting Load	Max. 60W Halogen Bulb or 13W PL Bulb
Additional Lighting Load	Max. 1,000W Incandescent or 500W Fluorescent
Detection Angle	Up to 180° at 20°C
Detection Distance	Up to 12M at 20°C
Mounting Height	Recommended 1.8 ~ 2.5M (5.9 ~ 8.2 Ft) Wall Mount
Wall Switch Control	On / Off / Manual Override
Sensor Operation	Auto
Time Adjustment	5 ± 3 sec. ~ 8 ± 3 min
Lux Adjustment	Activated when Lux below 50
Sensitivity Adjustment	Approx. 3~12M
Operating Temperature	-20°C ~ +40°C
Warm Up Time	About 1 min
Protection Class	Class II
Protection Degree	IP44
Safety	CE, GS