

TITAN

Stainless Steel Globe Lantern

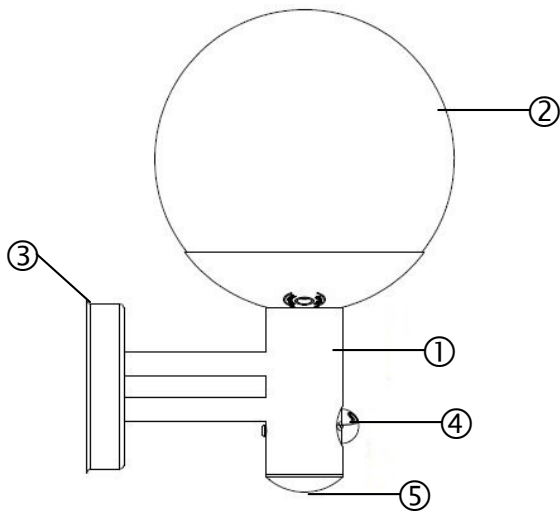

- ① Stainless Steel Housing
- ② Glass Diffuser
- ③ Wall Box Cover
- ④ PIR (Motion Sensor)
- ⑤ LED Comfort Light

INTRODUCTION

The Titan Stainless Steel Globe Lantern is designed for use outdoors.

The unit offers you an LED Comfort Light facility that is always on during the hours of darkness.

Also during the hours of darkness, the built-in passive infrared (PIR) sensor turns on the main Globe Light lamp when the PIR sensor detects a moving heat source in its coverage area. During daylight the built-in photocell saves energy by deactivating the LED Comfort Light and the main Globe Light lamp.

Note: Read this entire manual before you start to install the system.

SAFETY PRECAUTIONS

- DO NOT install when it is raining.
- Isolate the power supply before installation.
- UK Building Regulations require outdoor mains installations be carried out by a qualified electrician.
- BS7671: 2008 IEE Wiring Regulations must be complied with in all respects.
- HO5RNF round flexible cable and drip loops must be used to avoid water ingress damage to the unit.
- Ensure that the power supply is protected by a 6A circuit breaker or suitable fuse.
- Ensure minimum distance of 2.5m from objects in front of the unit.
- The unit must be installed vertically (FIGURE 1a) NOT at an angle (FIGURE 1b).

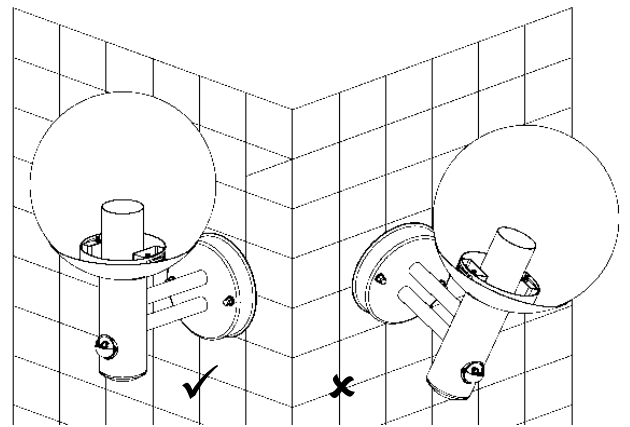

FIGURE 1a

FIGURE 1b

CHOOSING A MOUNTING LOCATION

- For the best results, mount the Globe Light onto normal brickwork 1.8~2.5m above the ground.
- Avoid aiming the PIR sensor at pools, heating vents, air conditioners or objects that may change temperature.
- Avoid pointing the PIR sensor at trees or shrubs or where the movement of pets or animals may be detected.
- Avoid locations where direct sunlight will shine onto the front of the PIR sensor for long periods, deterioration of the Fresnel lens may occur leading to poor triggering response.
- Prior to mounting, keep in mind that the PIR sensor is more sensitive to a heat source moving across its coverage area and less sensitive to a heat source that moves directly towards the PIR sensor (FIGURE 2).

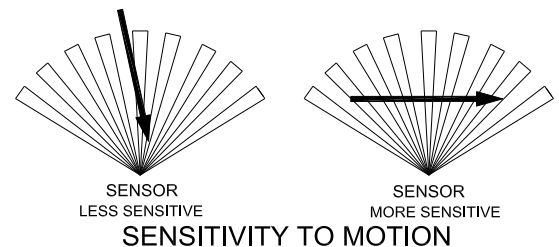

FIGURE 2

INSTALLATION

- For the best results, mount the Globe Light onto normal brickwork 1.8~2.5m above the ground.
- Unscrew the two nuts on the front plate of the unit.
- Position the mounting plate on the wall and mark the holes before drilling.
- There is an Up arrow on the mounting plate ensure this is pointing Up when marking the holes for drilling. FIGURE 3

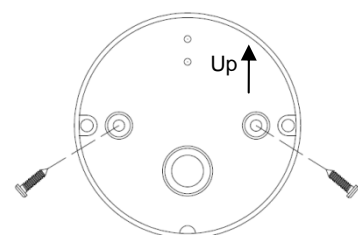

FIGURE 3

- Drill the holes and insert suitable wall plugs
- Use a bradawl to punch a small hole in the mounting plate cable grommet, to allow the supply cable to enter the mounting plate. FIGURE 4

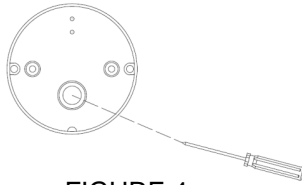



FIGURE 4

- Insert the supply cable through the grommet and fix the mounting plate to the wall using appropriate mounting screws.

WIRING INSTRUCTION

- (1) WARNING isolate the power supply.
- (2) An internal single pole wall switch is recommended to allow easy control of the Globe Light. FIGURE 5
- (3) Connect the supply cable to the unit. FIGURE 5 Strip approximately 6-8mm of inner core insulation from the supply cable.
- (4) Connect the BROWN wire (Live wire) to the terminal marked "L".
Connect the BLUE wire (Neutral wire) to the terminal marked "N".
Connect the GREEN/YELLOW wire to the terminal marked 

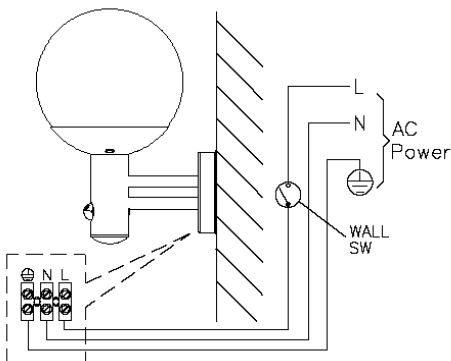

FIGURE 5

- (5) Fit the Globe Light to the mounting plate and secure with the two nuts. FIGURE 6

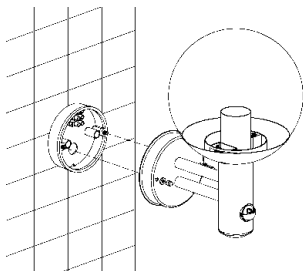

FIGURE 6

LAMP INSTALLATION

The Globe Light is suitable for use with a maximum lamp rating of either a 60w incandescent lamp or 13w fluorescent lamp with ES27 caps.

- (1) WARNING isolate the power supply or turn off the wall switch.

- (2) Turn the screws to the 'Open' position on the underside of the metal globe support. (FIGURE 7).

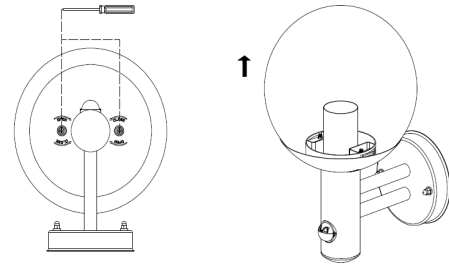

FIGURE 7

- (3) Lift off the glass globe and place carefully in a safe place so it does not get damaged. FIGURE 8

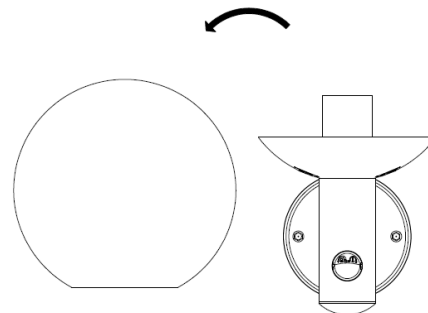

FIGURE 8

- (4) Insert the lamp into the lamp holder and turn clockwise to secure it. Do not over tighten. FIGURE 9

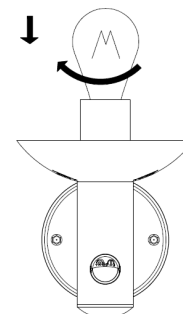

FIGURE 9

- (5) Refit the glass globe and support it in position whilst you turn the screws to the 'Close' position on the underside of the metal globe support.

SETTING UP

The PIR control cover can be adjusted to give the detection distance you require. FIGURE 10

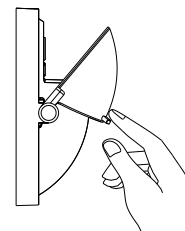

FIGURE 10

- For maximum detection range (12m) the control cover should be in the fully up position. FIGURE 11

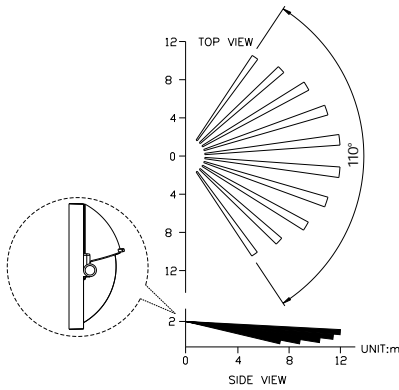

FIGURE 11

- For mid detection range (8m) the control cover should be in the mid position. FIGURE 12

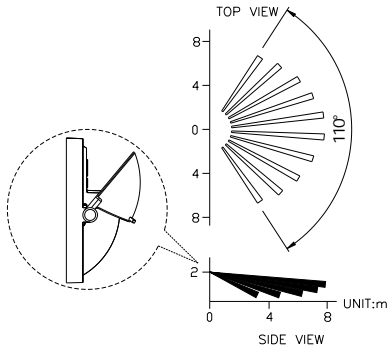

FIGURE 12

- For minimum detection range (4m) the control cover should be in the fully down position. FIGURE 13

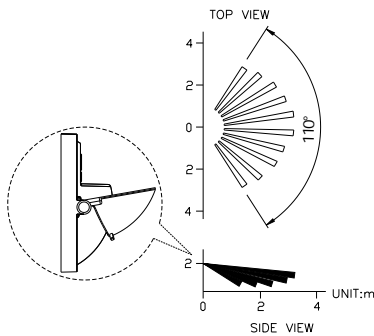

FIGURE 13

TESTING

For testing purposes move the control cover to the fully down position (FIGURE 13) to allow access to the PIR controls. Turn the power to the unit on and allow the unit to 'warm up' for approximately one minute.

Put the unit into test mode by turning the Time and Lux controls inside the control cover fully anticlockwise.

Walk through the detection area. The main lamp will turn on when you move and turn off when you stop. Wait for the lantern to turn off before moving again to test the sensor and to establish the best position for the control cover for your requirements. Once you have established the best position for the control cover,

maximum range, mid range or minimum range move the control cover to the fully down position (FIGURE 13) to finally set the Time and Lux control levels to your requirements.

SETTING TIME / LUX CONTROLS

(1) TIME ADJUSTMENT

The TIME adjustment controls how long the main lamp will stay on after motion has been detected.

Turn the TIME control clockwise to increase the time that the main lamp stays on. FIGURE 14

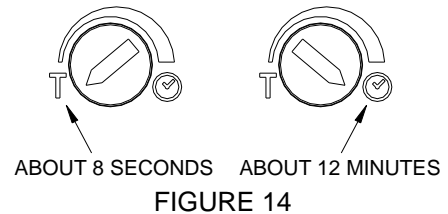

FIGURE 14

(2) LUX ADJUSTMENT

The LUX adjustment determines what light level the main lamp light will start to operate when the sensor is activated.

The recommended setting is fully clockwise to the moon (dusk) position. FIGURE 15. At this setting the motion sensor will remain inactive during daytime hours. When daylight fades at dusk the sensor will become active.



FIGURE 15

The comfort LED at the base of the unit also depends on the LUX setting. Using the recommended setting the comfort LED will come on at dusk and go off at dawn.

When you have completed the TIME and LUX settings return the control cover to the position you require established during the previous SETTING UP section.

Installation, testing and setting up is now completed and your unit is ready for normal use.

TROUBLESHOOTING

Main Lamp does not turn on when triggered

- Please check that your wiring connection is correct.
- Please make sure that the lamp is not blown.

Main Lamp does not turn off at night

- Please confirm that your wiring connection is correct.
- Check that the LUX Control is turned fully clockwise to the moon position.
- Please check if movement in the detection area is constantly triggering the PIR. To test this cover the PIR detector completely with black insulating tape so no triggers can be seen by the PIR. If the main lamp then turns off this means that the PIR can see a constant trigger such as bushes, trees or other moving heat sources.

SPECIFICATIONS

Power Requirement	AC 210 ~ 240V / 50Hz
Lamp Rating	Max. 13w Fluorescent or 60w incandescent lamp
Main Lamp Type	E27 Screw Type Max. length 180mm Max. diameter 55mm
LED Comfort Light	0.6W Photocell Controlled
PIR Sensor Angle	Up to 110° at 2m Height
Detection Range	Up to 12m at 2m Height
Mounting Height	Recommended 1.8 ~ 2.5m Wall Mount
Wall Switch Control	Power On/Off
Time Adjustment	8 secs ~ 12 mins
Lux Adjustment	30 ~200 Lux
Warm Up Time	About 60 seconds
Protection Class	Class 1 – Must be earthed
Protection Index	IP44

Specifications are subject to change without notice.

TITANTLGPIRSS

2015/07



Environmental Concerns:

Please DO NOT dispose of electrical appliances as unsorted waste, use the recycling facilities provided by your local authorities.

Please DO NOT dispose of packaging as unsorted waste, use the recycling facilities provided by your local authorities.